

Elegant NET

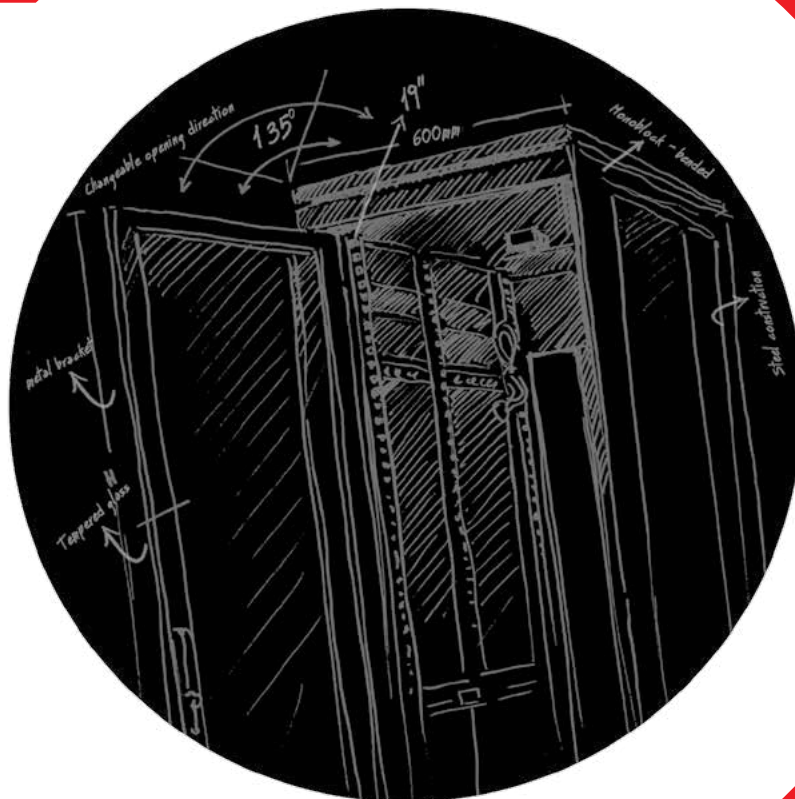



GÜNKO INDUSTRIAL

www.gunko.com.tr

INDUSTRIAL

Günko Industrial, one of Günko Group companies operating in the metal industry since 1974, was established in 2005.

Its modern technology according to an integrated infrastructure, experience and the needs of the IT world with dynamic staff presence of 19" indoor Racks and accessories, outdoor enclosures, server and data center cabinets.

All production processes are monitored and controlled by the ERP system.

Günko Industrial in the 19" rack industry in 2007 is the first enterprise engaged in the production of the EN standards, has been certified by TSE in 2010.

Its processes related to using the TS EN ISO 9001 Quality Management System and resources more effectively and efficiently control is continuous improvement.

Günko Industrial, within company boundaries, secure workspaces and safety work-related accidents by adopting a culture of prevention policies, to keep under control under the legal requirements and practices regarding enforcement of environmental legislation aims.

Günko Industrial pride of being the preferred brand comes from the excellent services offered to customers.



elegant pro

server rack

elegant net

open

rack

cabinets

pro case

soho rack

accessories

fiber optic

elegant wall

Elegant Wall

Elegant pro

Elegant Net

cabinets

Server

Accessories

fiber optic

Soho

Open

Pro case

Rack



woooow!!!

Günko desinged welded frame rack cabinets



We are aware of our responsibilities as Gunko industrial.

Elegant robust structure consist by front and rear welded frames.

19" Elegant Net & Elegant Pro rack cabinets are designed to meet the needs of high density network applications and it is engineered for superior weight capacity with welded construction.



%100 Recyclable packaging Materials

Elegant flat pack racks
less carbon footprint

Green advantages of fat pack

Do not forget your environmental responsibility

Compared to pre-assemble products flat pack rack cabinets is more environmentally conscious and it cuts down on size, which cuts down on shipping costs and also reduces the carbon footprint for a green Nature environment.



Elegant flat pack Rack cabinets enables consumers to assemble a product themselves with a manual instruction, saving significant amounts of money for the customers by reducing shipping and storage costs and for the consumers it offers an easier shape / size to carry.

You can not change the structure of the buildings but you can order Flat pack Elegant rack (all in 1 pack)

Easy transportation for retail customers



Door / Elevator

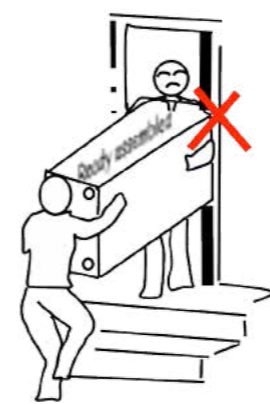

Thanks to Flat pack construction it is possible to bring them also into places with difficult access, e.g. basement or attic, narrow door-openings or spiral stairs.

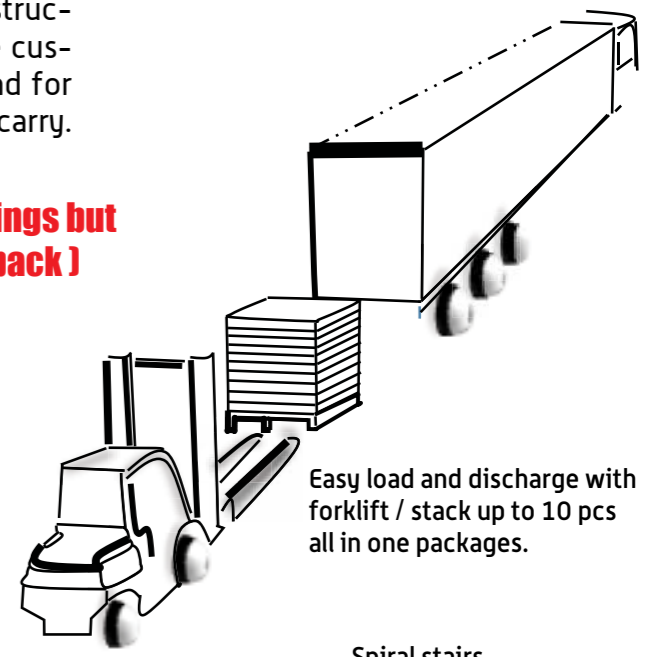

Easy load and discharge with forklift / stack up to 10 pcs all in one packages.

Spiral stairs





Elegant Net



elegant net cabinets

2

Cabinets

www.gunco.com.tr



Elegant NET 600

IT Rack Cabinet

Elegant NET IT rack series offers the permanent solution for management of Network devices and cables. The unique, flexible and effective range is the ideal solution to support the Network and server applications with its welded and durable structure.

Elegant NET IT rack networking Cabinet are intended for installation of data and telecommunication devices and their distribution systems. Mostly used for structured network cabling systems in office environments, Also to be used in computer-rooms and small or large sized data-centers. A lot of options for doors, side-and rear panels, as well as many different accessories, make the use of the enclosure very flexible.

Vertical mounting rails are adjustable throughout the entire depth of the cabinet and have very high carrying capacity with 1.5mm thickness. Silk-screen mounting rails are providing ability to count U-Marking from top to down & down to up for easy device installation.

Removable side and rear panels allow comfortable and easy access to the installed devices for maintenance from all sides of the cabinet. For active cooling, it is possible to install an optional fan-unit into the roof and/or floor. Due to flat-pack construction it is possible to bring them also into places with difficult access, basement or attic, in the narrow entrance or stairs.

We are responding the needs of users with choice of 9 different height dimensions.

Height : 12U-16U-20U-22U-26U-32U-36U-42U-45U-47U
 Width : 600mm
 Depth: 600mm & 800mm & 1000mm

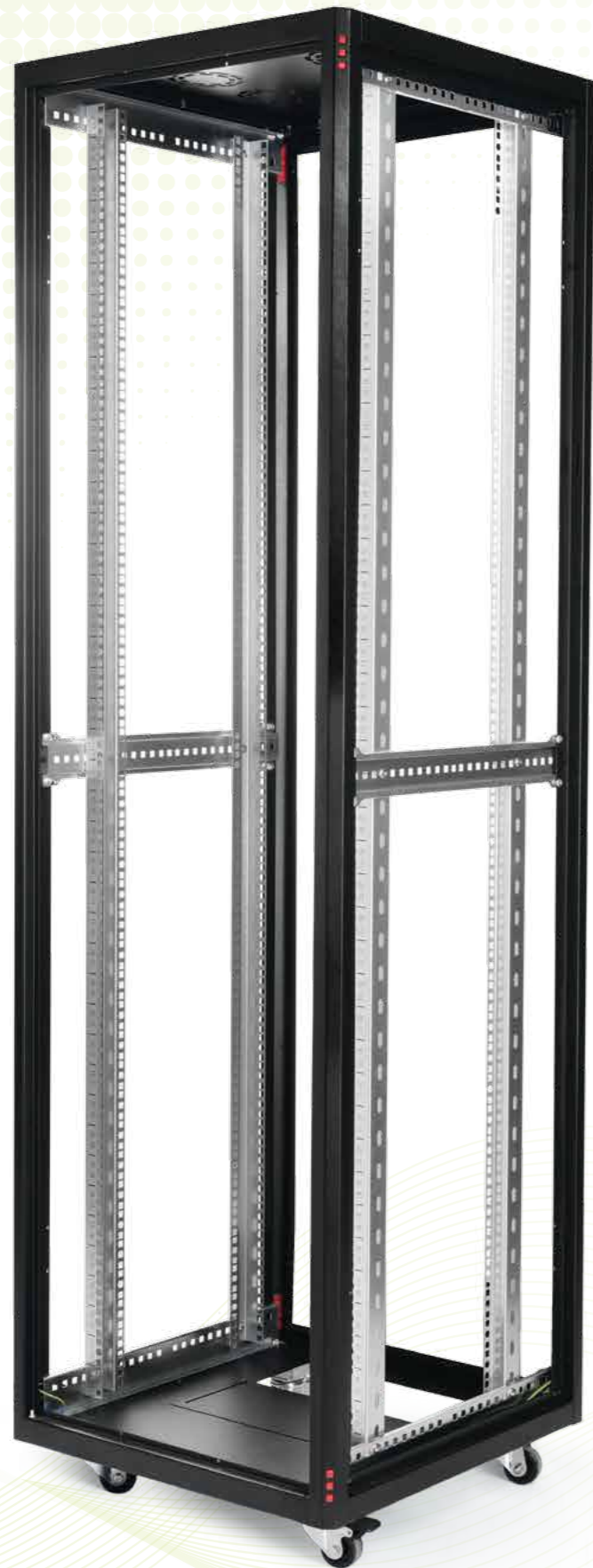

Elegant NET 600 IT Rack Cabinet

Quick-change fan tray allows accessibility without removing the cables or active devices from the rack in case of any maintenance or replacement needs.

Elegant NET ; Top cover has been designed for ventilation module which can be detached by removing 4 pcs screws from the top in case of maintenance or replacement needs.

Protect your device against overheating by choosing the right fan module.

We offer a wide product range of ventilation units with the different fan modules.

On/Off switch Fan modules Analog or digital
Thermostat control unit Fan modules



Professional Network Cabinets

Elegant NET
IT-Rack Cabinet

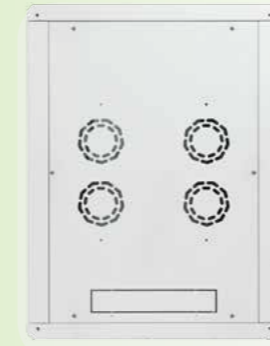

M-joint cable entry panels located on the top cover designed for easy cabling and High-density cabling.

Dimensions w: 300 - D: 56 mm



Sliding cable entry panels located on the bottom plates has been designed for easy cabling and High-density cabling by using sliding cable entry panels with the dimensions w: 300 - D: 125 mm



Vertical mounting rails are adjustable throughout the entire depth of the cabinet and have very high carrying capacity with 1.5mm thickness, Silk-screen mounting rails are providing ability to count U- Marking from top to down & down to up for easy device installation



Castors

Castor and/or levelling feet could be mounted on to rack.

Elegant NET 600

IT Rack Cabinet

Door options / W: 600 mm

The front door is designed to provide security with lock mechanism and decorative view together, full-length smoked and shatterproof glass door deployed in metal frame, easily rotated to the left

or right directions by special spring hinge, in case of needs 3 points and single point locking systems are available depends on customer requirements.

Easily removable side panels complete with Barrel lock & Sliding latch locks

RAL 9005-Black (Standard Colour)
RAL 7035-Light Gray (Optional)



elegant net cabinets

%80 Curved Perforated Metal Door-Single



%63 Curved Perforated Metal Door-Single



Flat Metal Door-Single



Tempered Glass Door-Single



%80 Perforated Metal Door-Double



%63 Perforated Metal Door-Double



Flat Metal Door-Single



Technical Drawing
W: 600 mm d: 600 mm

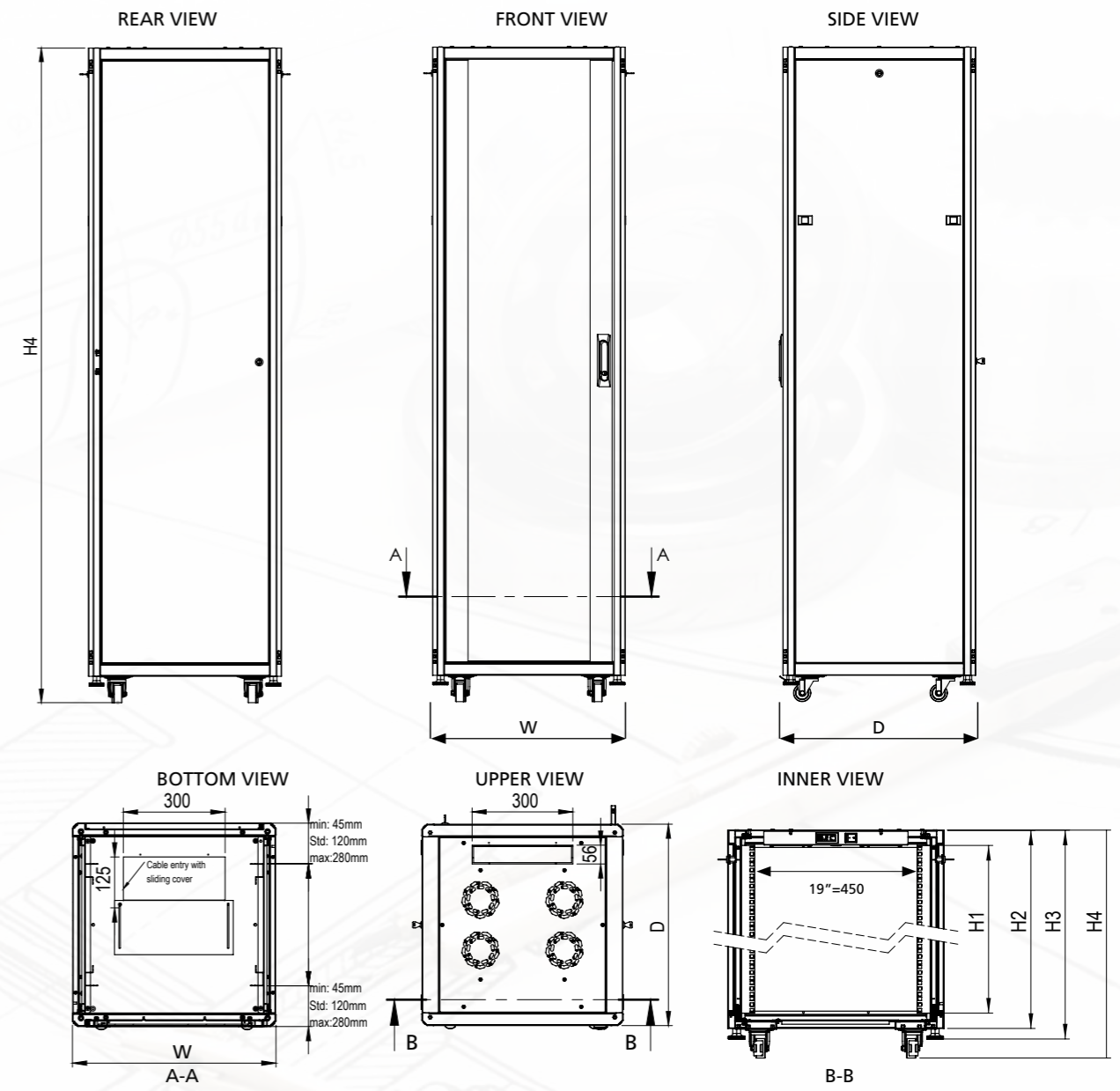
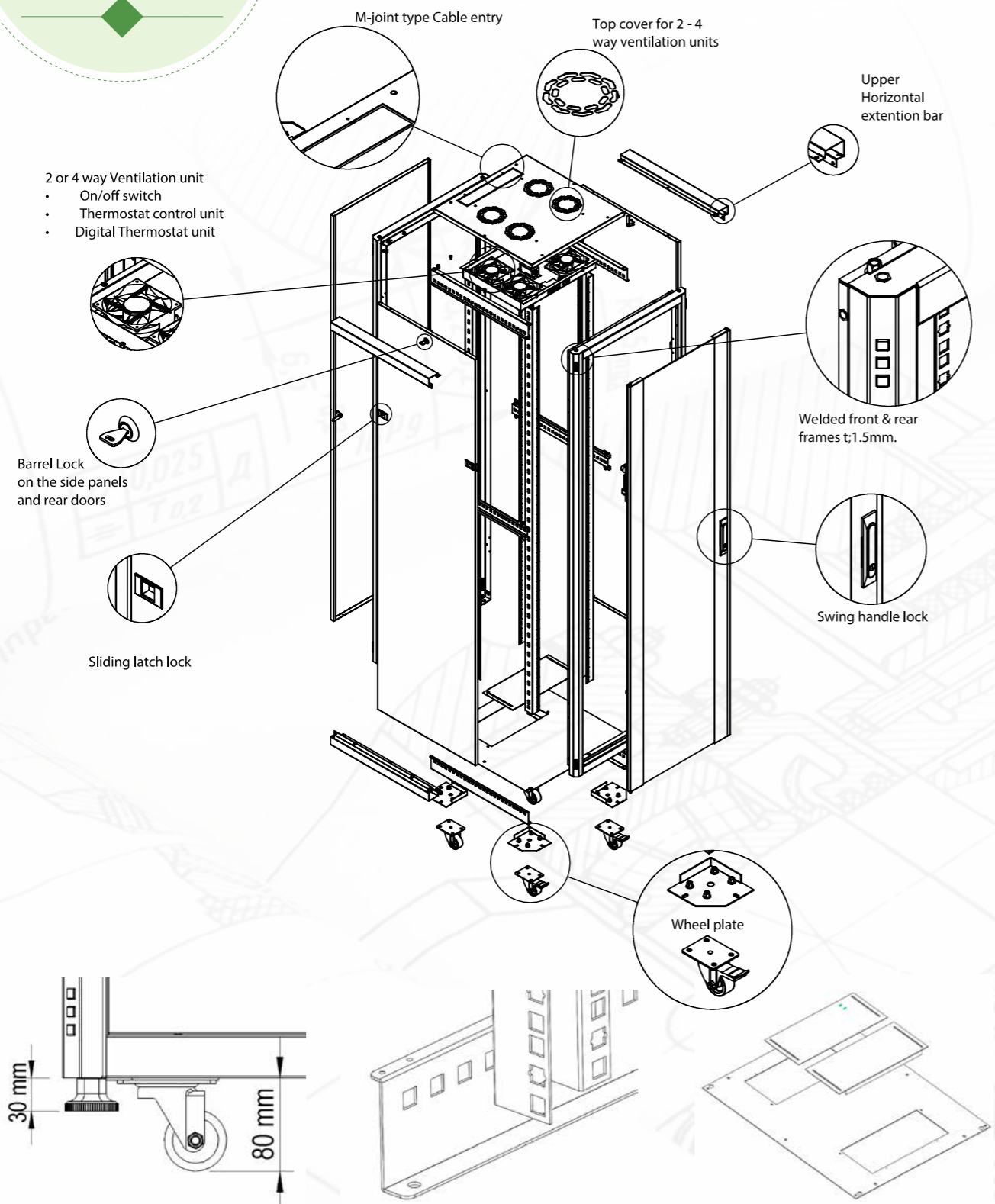

600 x 600 mm FLOOR STANDING ELEGANT NET

Product Code	Product Description	Out Width (W) (mm)	Out Depth (D) (mm)	H:1 Inner Height (mm)	H:2 Out Height without feet & wheel set (mm)	H:3 Out Height with levelling feet (mm)	H:4 Out Height with wheel set (mm)
ELGN 12U 6060 CC 111	Elegant NET 19" 12U W=600 mm D=600 mm	600	600	536,6	621,5	651,5	701,5
ELGN 16U 6060 CC 111	Elegant NET 19" 16U W=600 mm D=600 mm	600	600	714,4	799,3	829,3	879,3
ELGN 20U 6060 CC 111	Elegant NET 19" 20U W=600 mm D=600 mm	600	600	892,2	977,1	1007,1	1057,1
ELGN 22U 6060 CC 111	Elegant NET 19" 22U W=600 mm D=600 mm	600	600	981,1	1066	1096	1146
ELGN 26U 6060 CC 111	Elegant NET 19" 26U W=600 mm D=600 mm	600	600	1158,9	1243,8	1273,8	1323,8
ELGN 32U 6060 CC 111	Elegant NET 19" 32U W=600 mm D=600 mm	600	600	1425,6	1510,5	1540,5	1590,5
ELGN 36U 6060 CC 111	Elegant NET 19" 36U W=600 mm D=600 mm	600	600	1603,4	1688,3	1718,3	1768,3
ELGN 42U 6060 CC 111	Elegant NET 19" 42U W=600 mm D=600 mm	600	600	1870,1	1955	1985	2035
ELGN 45U 6060 CC 111	Elegant NET 19" 45U W=600 mm D=600 mm	600	600	2003,45	2088,35	2118,35	2168,35
ELGN 47U 6060 CC 111	Elegant NET 19" 47U W=600 mm D=600 mm	600	600	2092,35	2177,25	2207,25	2257,25

**CC Means=Color Code, BL=Rall 9005 Black, LG=Rall 7035 Light Gray

Technical Drawing
W: 600 mm d: 800 mm

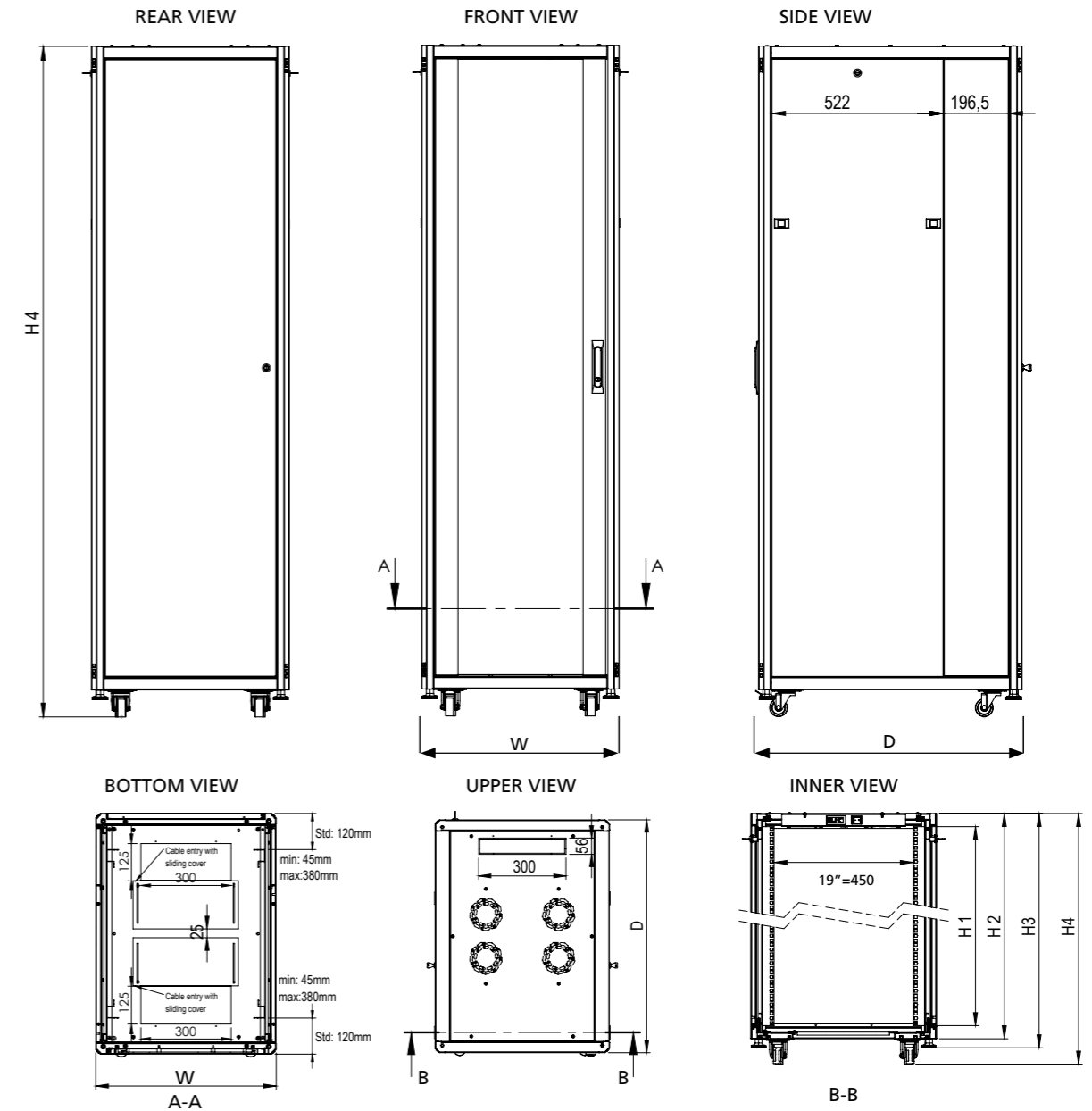
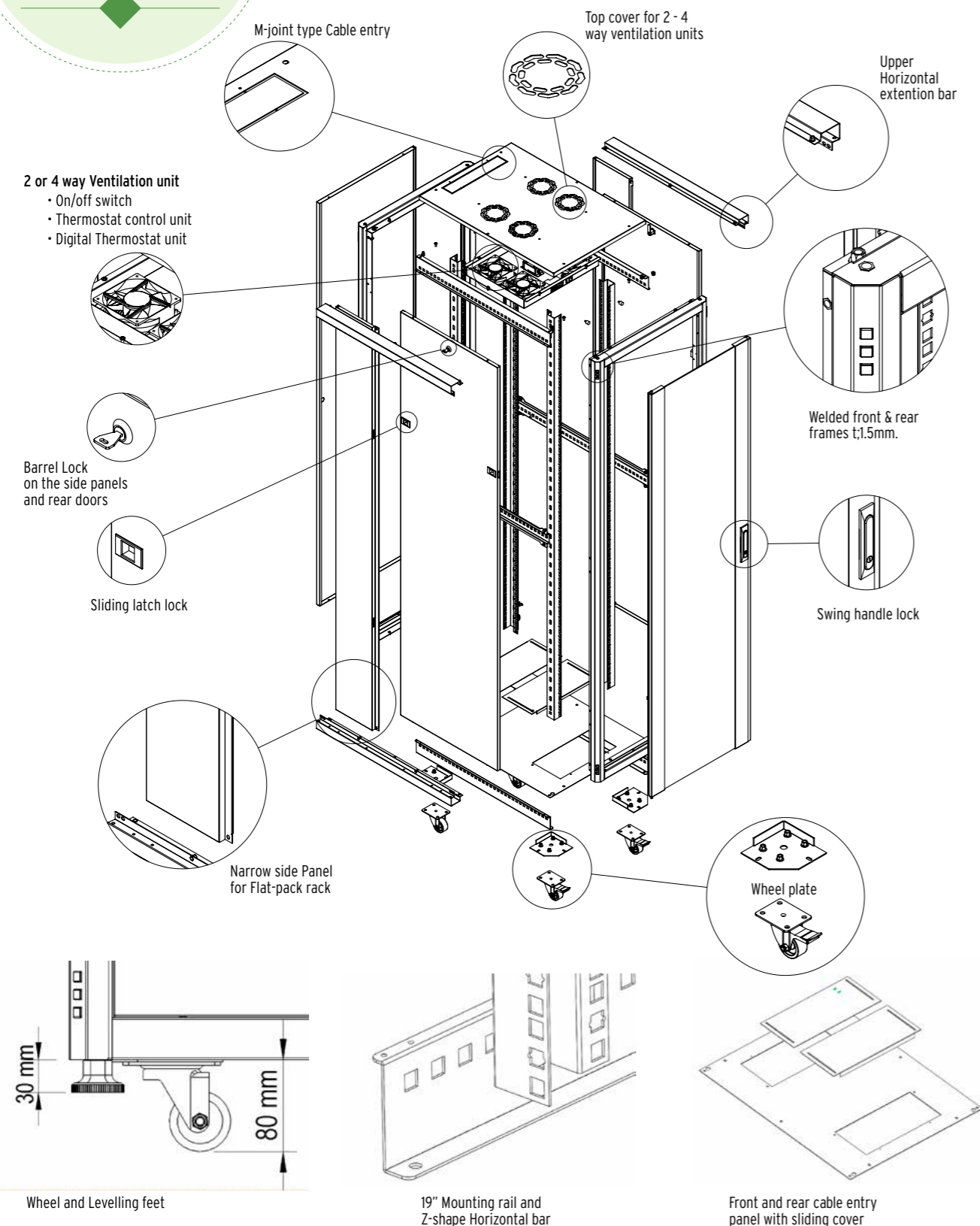

600 x 800 mm FLOOR STANDING ELEGANT NET

Product Code	Product Description	Out Width (W) (mm)	Out Depth (D) (mm)	H:1 Inner Height (mm)	H:2 Out Height without feet & wheel set (mm)	H:3 Out Height with levelling feet (mm)	H:4 Out Height with wheel set (mm)
ELGN 12U 6080 CC 111	Elegant NET 19" 12U W=600 mm D=800 mm	600	800	536,6	621,5	651,5	701,5
ELGN 16U 6080 CC 111	Elegant NET 19" 16U W=600 mm D=800 mm	600	800	714,4	799,3	829,3	879,3
ELGN 20U 6080 CC 111	Elegant NET 19" 20U W=600 mm D=800 mm	600	800	892,2	977,1	1007,1	1057,1
ELGN 22U 6080 CC 111	Elegant NET 19" 22U W=600 mm D=800 mm	600	800	981,1	1066	1096	1146
ELGN 26U 6080 CC 111	Elegant NET 19" 26U W=600 mm D=800 mm	600	800	1158,9	1243,8	1273,8	1323,8
ELGN 32U 6080 CC 111	Elegant NET 19" 32U W=600 mm D=800 mm	600	800	1425,6	1510,5	1540,5	1590,5
ELGN 36U 6080 CC 111	Elegant NET 19" 36U W=600 mm D=800 mm	600	800	1603,4	1688,3	1718,3	1768,3
ELGN 42U 6080 CC 111	Elegant NET 19" 42U W=600 mm D=800 mm	600	800	1870,1	1955	1985	2035
ELGN 45U 6080 CC 111	Elegant NET 19" 45U W=600 mm D=800 mm	600	800	2003,45	2088,35	2118,35	2168,35
ELGN 47U 6080 CC 111	Elegant NET 19" 47U W=600 mm D=800 mm	600	800	2092,35	2177,25	2207,25	2257,25

**CC Means=Color Code, BL=Rall 9005 Black, LG=Rall 7035 Light Gray

Technical Drawing
 W: 600 mm D: 1000 mm

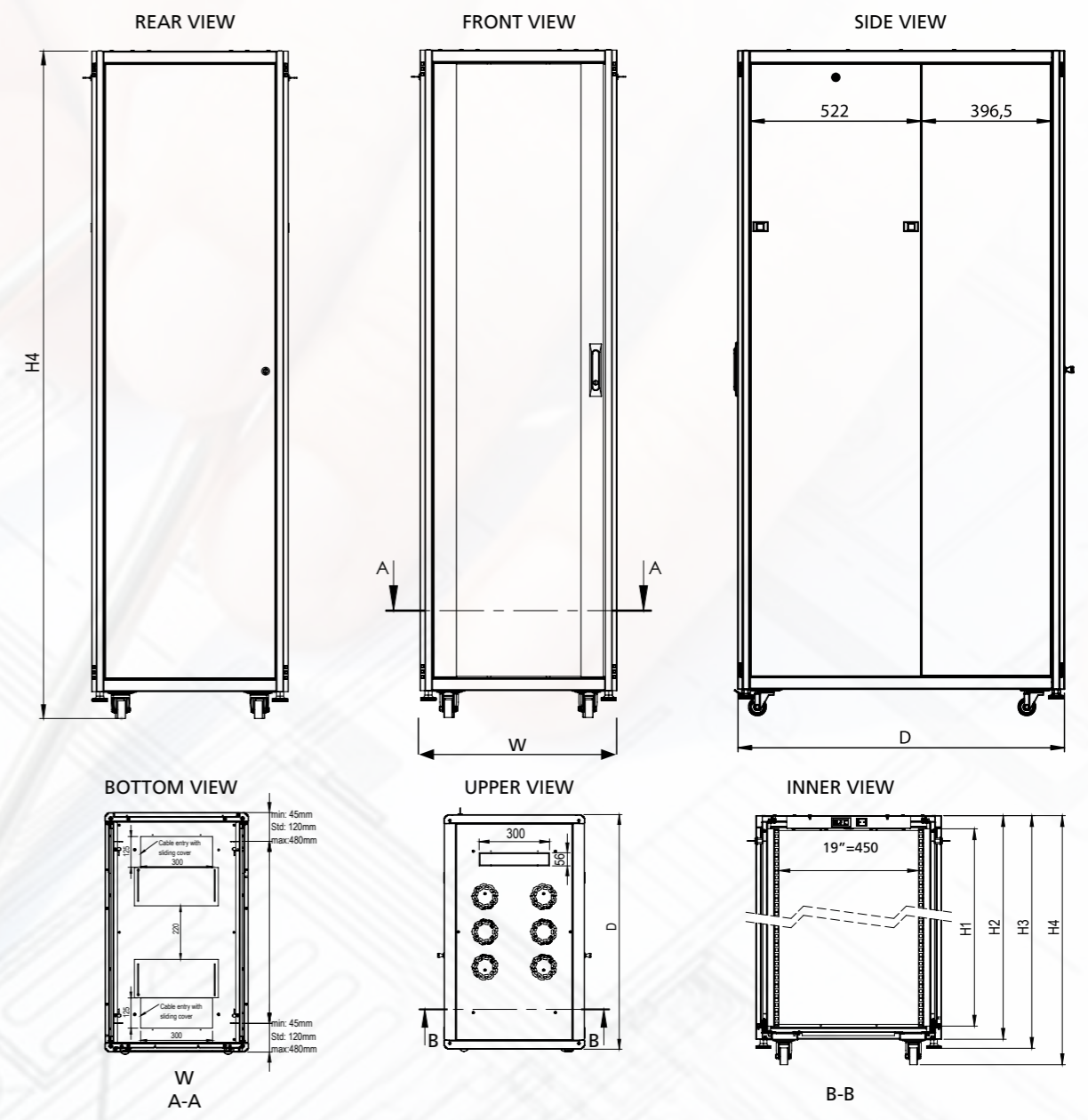
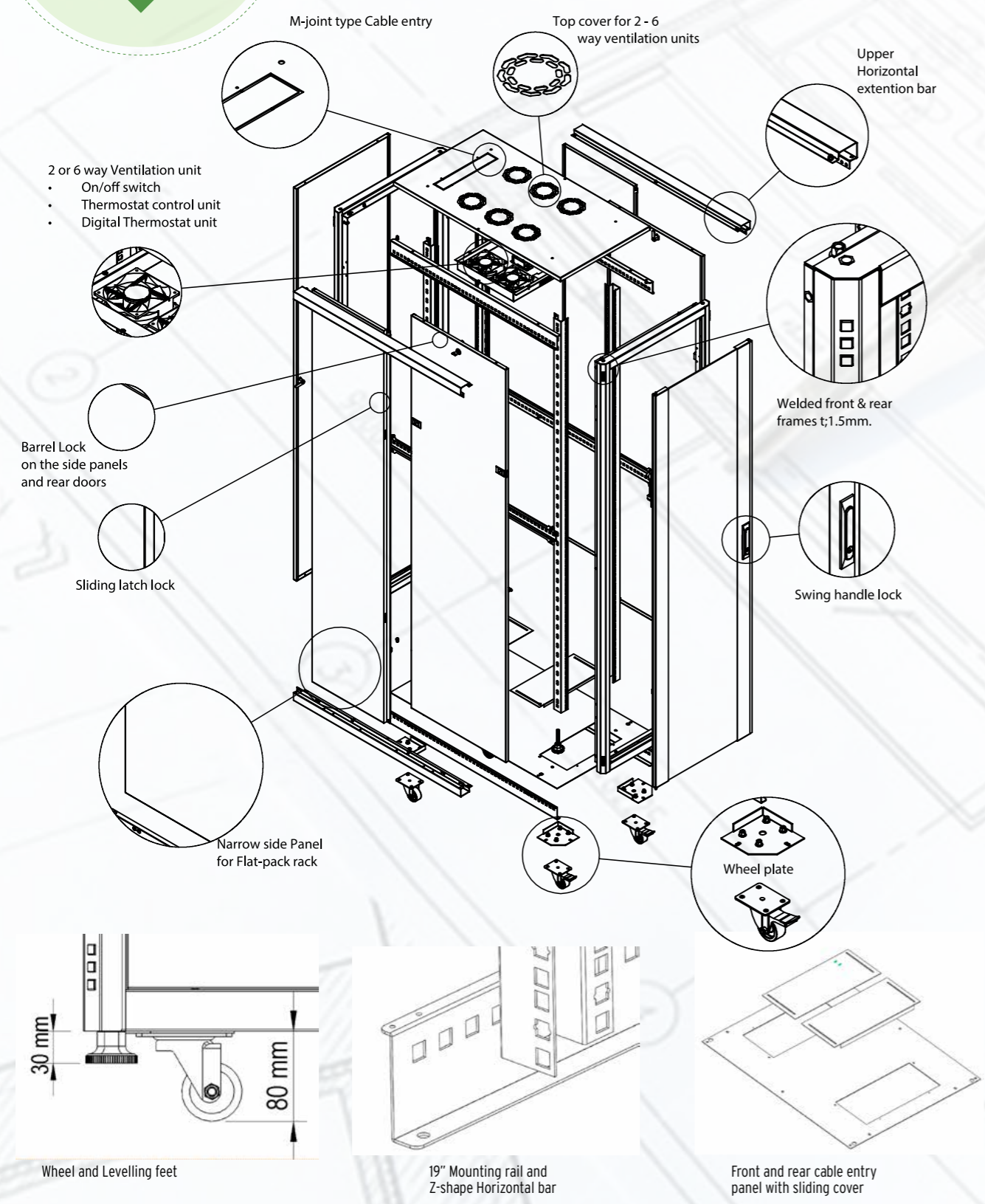

600 x 1000 mm FLOOR STANDING ELEGANT NET

Product Code	Product Description	Out Width (W) (mm)	Out Depth (D) (mm)	H:1 Inner Height (mm)	H:2 Out Height without feet & wheel set (mm)	H:3 Out Height with levelling feet (mm)	H:4 Out Height with wheel set (mm)
ELGN 12U 6010 CC 111	Elegant NET 19" 12U W=600 mm D=1000 mm	600	1000	536,6	621,5	651,5	701,5
ELGN 16U 6010 CC 111	Elegant NET 19" 16U W=600 mm D=1000 mm	600	1000	714,4	799,3	829,3	879,3
ELGN 26U 6010 CC 111	Elegant NET 19" 26U W=600 mm D=1000 mm	600	1000	1158,9	1243,8	1273,8	1323,8
ELGN 32U 6010 CC 111	Elegant NET 19" 32U W=600 mm D=1000 mm	600	1000	1425,6	1510,5	1540,5	1590,5
ELGN 36U 6010 CC 111	Elegant NET 19" 36U W=600 mm D=1000 mm	600	1000	1603,4	1688,3	1718,3	1768,3
ELGN 42U 6010 CC 111	Elegant NET 19" 42U W=600 mm D=1000 mm	600	1000	1870,1	1955	1985	2035
ELGN 45U 6010 CC 111	Elegant NET 19" 45U W=600 mm D=1000 mm	600	1000	2003,45	2088,35	2118,35	2168,35
ELGN 47U 6010 CC 111	Elegant NET 19" 47U W=600 mm D=1000 mm	600	1000	2092,35	2177,25	2207,25	2257,25

**CC Means=Color Code, BL=Rall 9005 Black, LG=Rall 7035 Light Gray

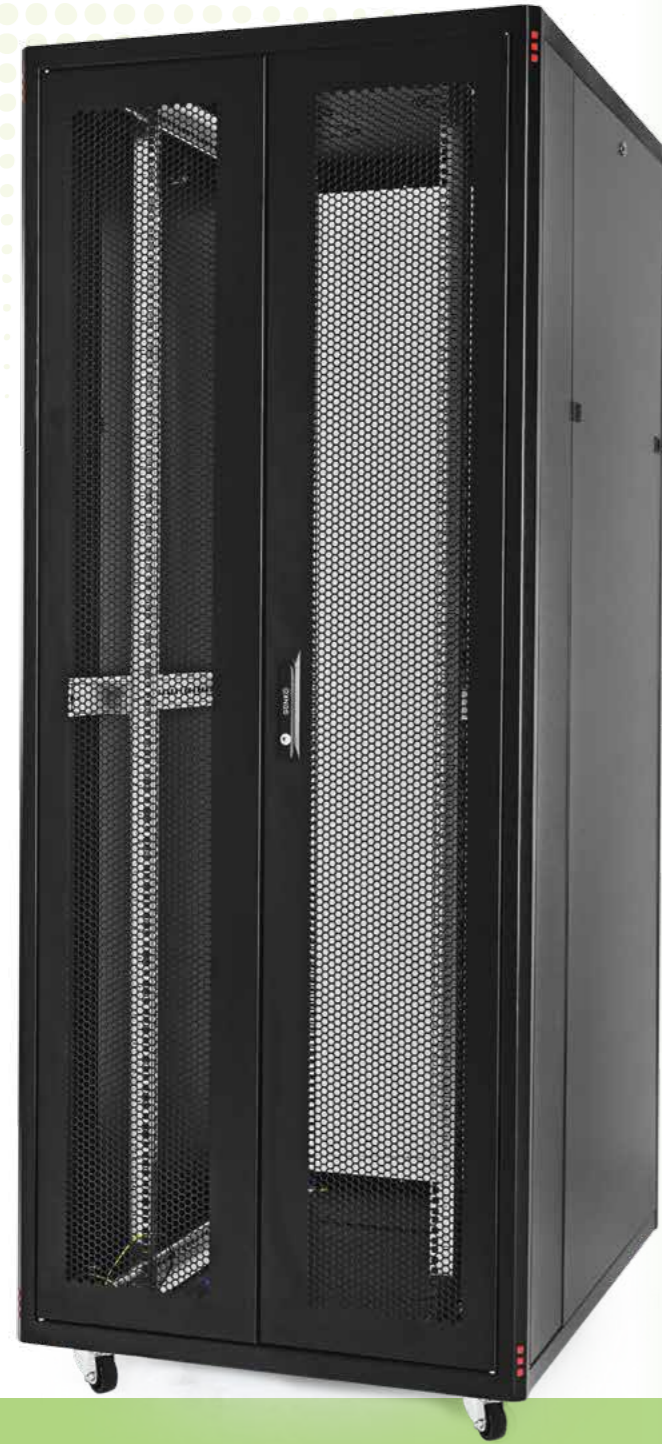

Elegant NET
IT Rack Cabinet

Elegant NET 800

IT Rack Cabinet

**Network installers will be quite satisfied when needed
Large internal volume during the installation**

Elegant Net IT rack series offers the permanent solution for management of Network devices and cables. The unique, flexible and effective range is the ideal solution to support the Network and server applications with its welded and durable structure.

Elegant IT rack networking Cabinet are intended for installation of data and telecommunication devices and their distribution systems. Mostly used for structured network cabling systems in office environments, Also to be used in computer-rooms and small or large sized data-centers. A lot of options for doors, side- and rear panels, as well as many different accessories, make the use of the enclosure very flexible.

Vertical mounting rails are adjustable throughout the entire depth of the cabinet and have very high carrying capacity with 1.5mm thickness Silk-screen mounting rails are providing ability to count U- Marking from top to down & down to up for easy device installation

Removable side and rear panels allow comfortable and easy access to the installed devices for maintenance from all sides of the cabinet. For active cooling, it is possible to install an optional fan-unit into the roof and/or floor. Due to flat-pack construction it is possible to bring them also into places with difficult access, basement or attic, In the narrow entrance or stairs.

Width=800mm Elegant Net - Huge IT rack cabinets are designed for housing the Patch panels, switching installation, patch cord / cable management both horizontally or vertically positions

it allows for cable management of the each side of 19" mounting rails with or without Vertical cable management block / Vertical cable management with sliding panel and its the simple, flexible and cost-effective way to organize your cable bundles and patch cords, The Cabins are optimized to meet the modern network and structured cabling requirements.



We are responding the needs of users with choice of 5 different height dimensions.

Height : 26U-32U-36U-42U-45U-47U
Width : 800mm
Depth : 800mm & 1000mm

Elegant NET 800

IT Rack Cabinet

Quick-change fan tray allows accessibility without removing the cables or active devices from the rack in case of any maintenance or replacement needs.

Elegant NET; Top cover has been designed for ventilation module which can be detached by removing 4 pcs screws from the top in case of maintenance or replacement needs.

Protect your device against overheating by choosing the right fan module.

We offer a wide product range of ventilation units with the different fan modules.

On/Off switch Fan modules, Analog & Digital Thermostat control unit Fan modules.



M-joint cable entry panels located on the top cover designed for easy cabling and High-density cabling.
Dimensions w: 300 – D: 56 mm



Sliding cable entry panels located on the bottom plates has been designed for easy cabling and High-density cabling by using sliding cable entry panels with the dimensions w: 300 – D: 125 mm



Vertical mounting rails are adjustable throughout the entire depth of the cabinet and have very high carrying capacity with 1.5mm thickness, Silk-screen mounting rails are providing ability to count U- Marking from top to down & down to up for easy device installation



Castors

Castor and/or levelling feet could be mounted on to rack.

Elegant NET 800

IT Rack Cabinet

Door options / W: 800 mm

The front door is designed to provide security with lock mechanism and decorative view together, full-length smoked and shatterproof glass door deployed in metal frame, easily rotated to the left

or right directions by special spring hinge, in case of needs 3 points and single point locking systems are available with single glass instead of splitted glasses depends on customer requirements.

Easily removable side panels complete with Barrel lock & Sliding latch locks

RAL 9005-Black (Standard Colour)
RAL 7035-Light Gray (Optional)



elegant net cabinets

%80 Curved Perforated Metal Door-Single



%63 Curved Perforated Metal Door-Single



Flat Metal Door-Double



Tempered Glass Door-Double

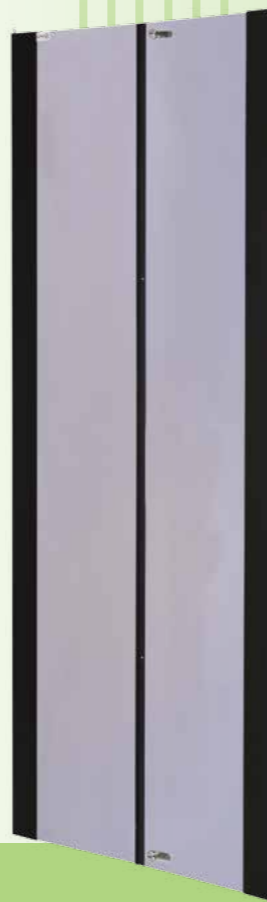

%80 Perforated Metal Door-Double



%63 Perforated Metal Door-Double



Flat Metal Door-Double



Technical Drawing
w:800 mm d:800 mm

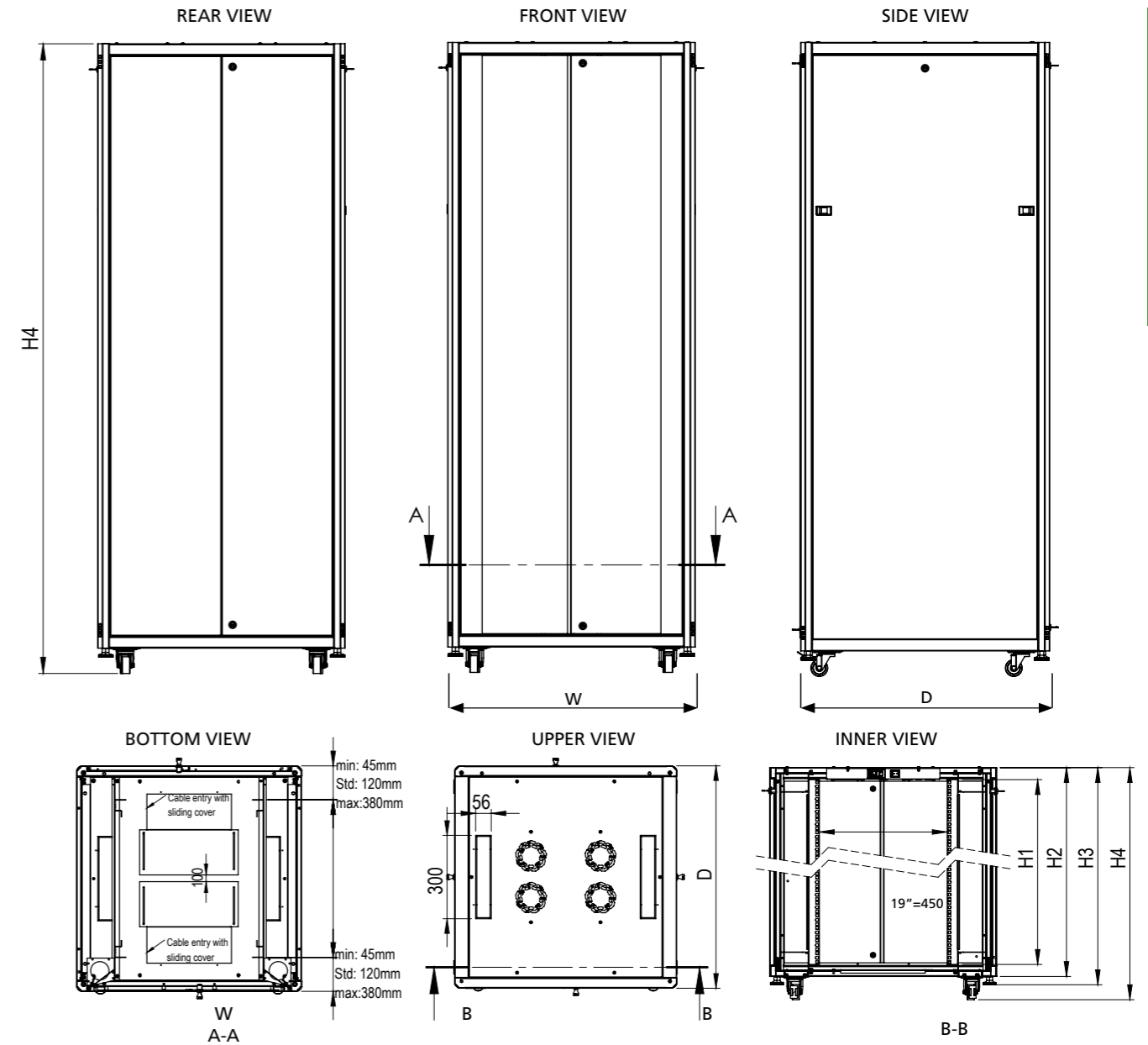
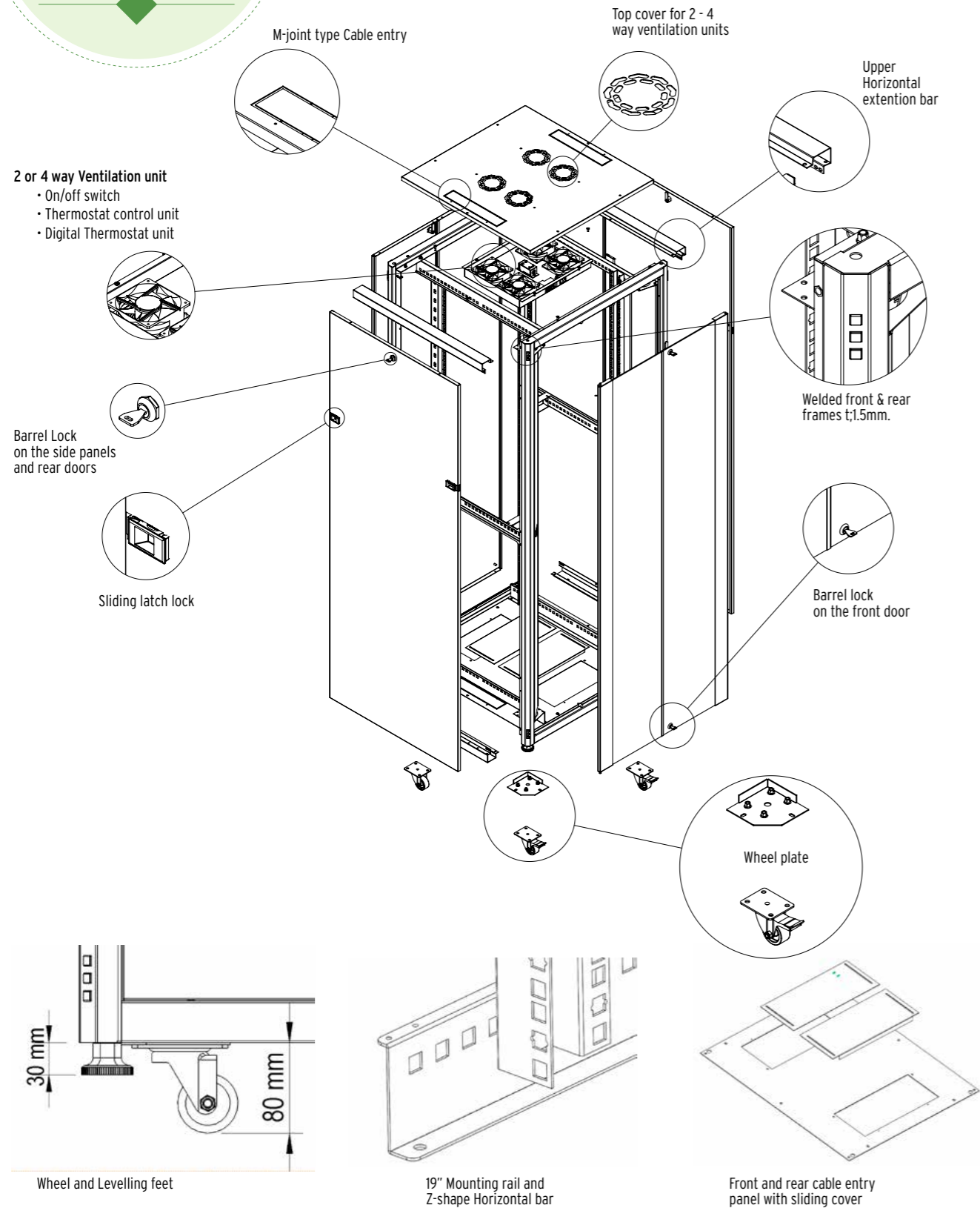

800 x 800 mm FLOOR STANDING ELEGANT NET

Product Code	Product Description	Out Width (W) (mm)	Out Depth (D) (mm)	H:1 Inner Height (mm)	H:2 Out Height without feet & wheel set (mm)	H:3 Out Height with levelling feet (mm)	H:4 Out Height with wheel set (mm)
ELGN 26U 8080 CC 221	Elegant NET 19" 26U W=800 mm D=800 mm	800	800	1158,9	1243,8	1273,8	1323,8
ELGN 32U 8080 CC 221	Elegant NET 19" 32U W=800 mm D=800 mm	800	800	1425,6	1510,5	1540,5	1590,5
ELGN 36U 8080 CC 221	Elegant NET 19" 36U W=800 mm D=800 mm	800	800	1603,4	1688,3	1718,3	1768,3
ELGN 42U 8080 CC 221	Elegant NET 19" 42U W=800 mm D=800 mm	800	800	1870,1	1955	1985	2035
ELGN 45U 8080 CC 221	Elegant NET 19" 45U W=800 mm D=800 mm	800	800	2003,45	2088,35	2118,35	2168,35
ELGN 47U 8080 CC 221	Elegant NET 19" 47U W=800 mm D=800 mm	800	800	2092,35	2177,25	2207,25	2257,25

**CC Means=Color Code, BL=Rall 9005 Black, LG=Rall 7035 Light Gray

Technical Drawing
w:800 mm d:1000 mm

elegant net cabinets

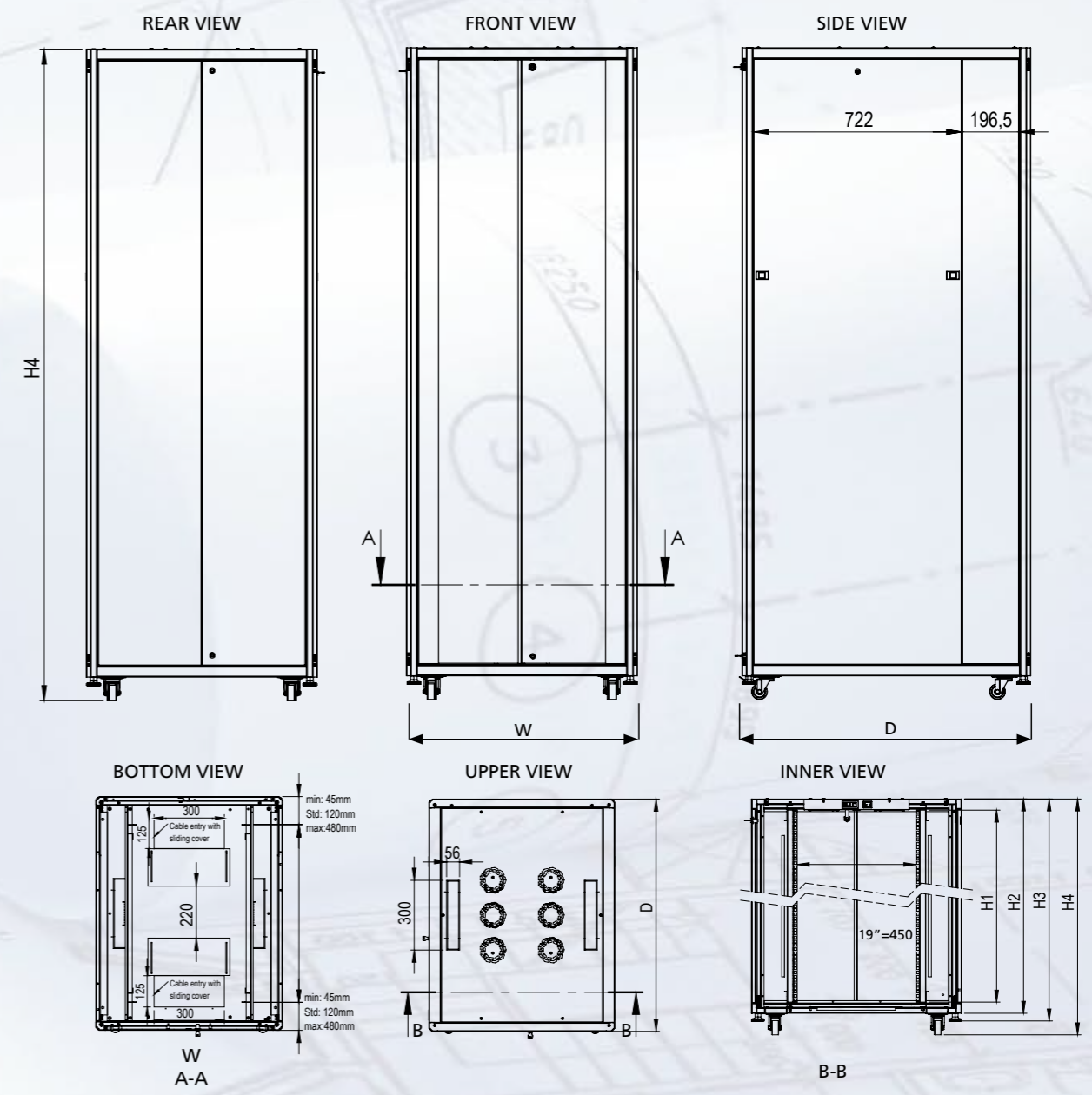
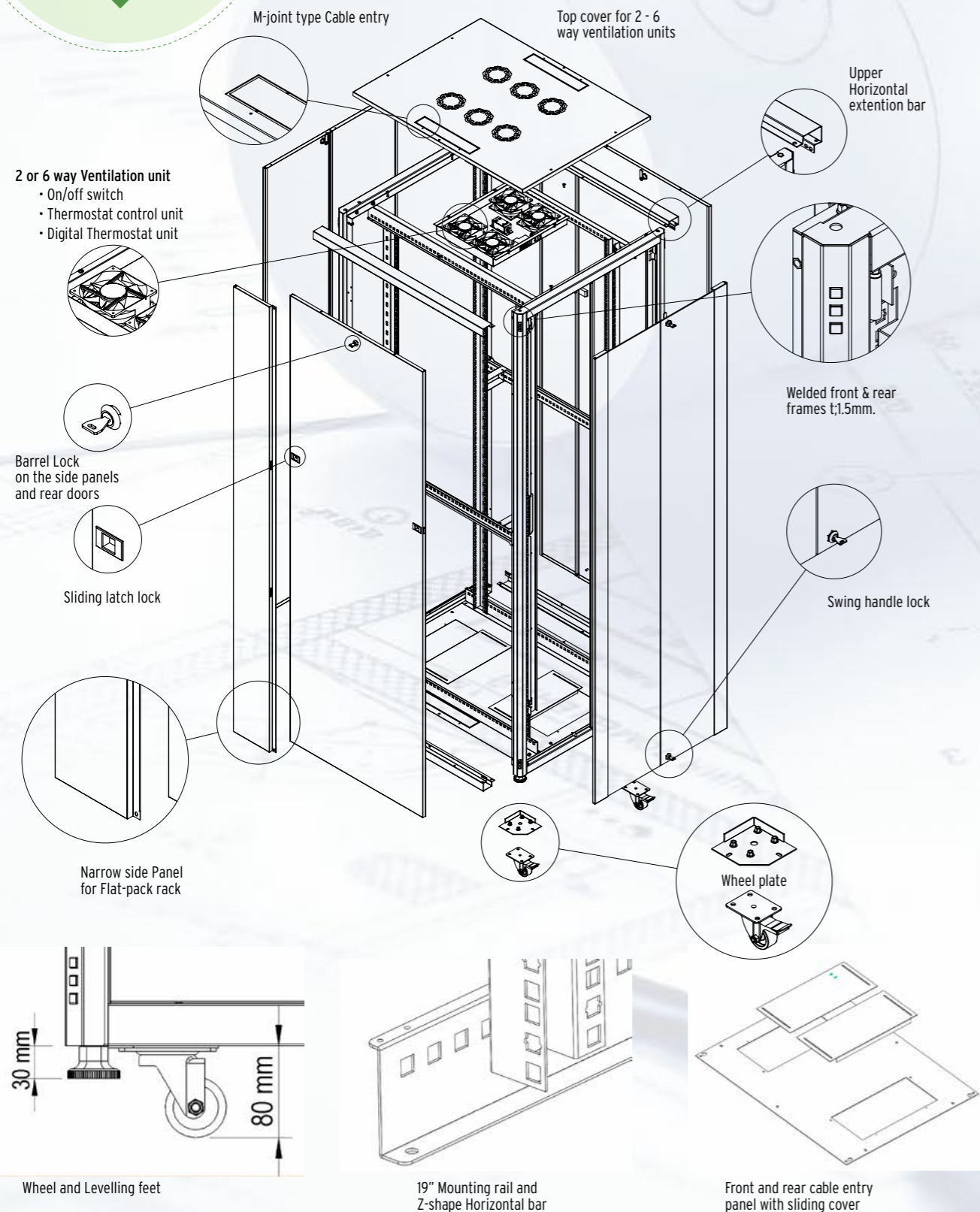

800 x 1000 mm FLOOR STANDING ELEGANT NET

Product Code	Product Description	Out Width (W) (mm)	Out Depth (D) (mm)	H:1 Inner Height (mm)	H:2 Out Height without feet & wheel set (mm)	H:3 Out Height with levelling feet (mm)	H:4 Out Height with wheel set (mm)
ELGN 26U 8010 CC 221	Elegant NET 19" 26U W=800 mm D=1000 mm	800	1000	1158,9	1243,8	1273,8	1323,8
ELGN 32U 8010 CC 221	Elegant NET 19" 32U W=800 mm D=1000 mm	800	1000	1425,6	1510,5	1540,5	1590,5
ELGN 36U 8010 CC 221	Elegant NET 19" 36U W=800 mm D=1000 mm	800	1000	1603,4	1688,3	1718,3	1768,3
ELGN 42U 8010 CC 221	Elegant NET 19" 42U W=800 mm D=1000 mm	800	1000	1870,1	1955	1985	2035
ELGN 45U 8010 CC 221	Elegant NET 19" 45U W=800 mm D=1000 mm	800	1000	2003,45	2088,35	2118,35	2168,35
ELGN 47U 8010 CC 221	Elegant NET 19" 47U W=800 mm D=1000 mm	800	1000	2092,35	2177,25	2207,25	2257,25

**CC Means=Color Code, BL=Rall 9005 Black, LG=Rall 7035 Light Gray

W600
Curved Perforated

FRONT VIEW



REAR VIEW



FRONT VIEW



REAR VIEW

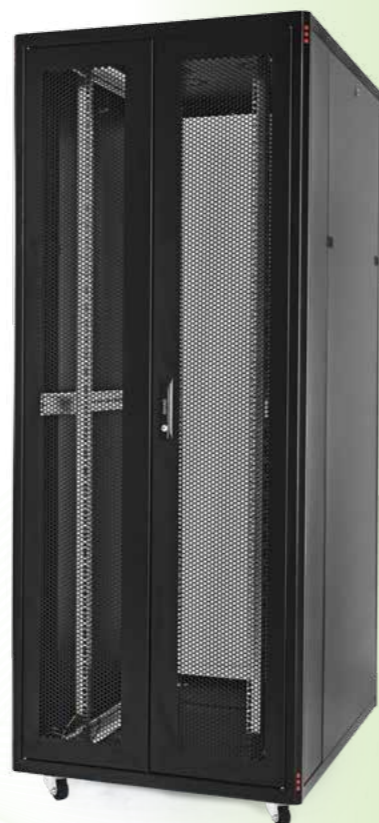

W800
Curved Perforated



**We believe
You deserve the
best infrastructure
solutions**



Elegant Net Provides Economic and Durable Solutions

Benefits Of The Excellent Cabling

- Maximised Cabling Paths Or Optized System Performance
- Proper Cabling
- Easy Cabletracing
- Easy Cable Replacing
- Easily Removing Hardware
- Increasing The Airflow Ability Against The Overheating Devices Because Of Wrong Located Cable Bundles.