

Elegant PRO

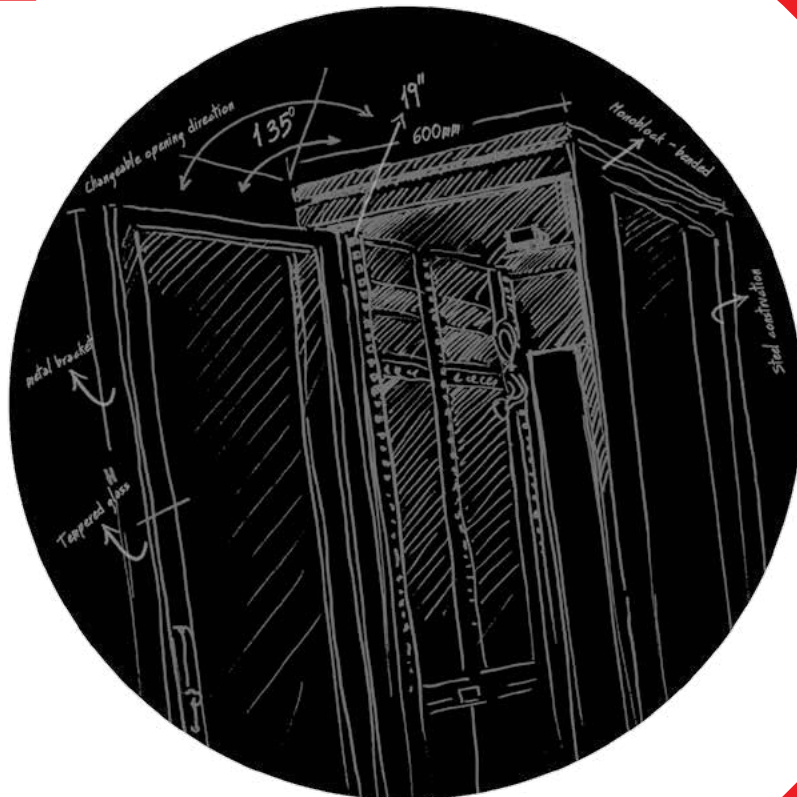



GÜNKO INDUSTRIAL

www.gunko.com.tr

INDUSTRIAL

Günko Industrial, one of Günko Group companies operating in the metal industry since 1974, was established in 2005.

Its modern technology according to an integrated infrastructure, experience and the needs of the IT world with dynamic staff presence of 19" indoor Racks and accessories, outdoor enclosures, server and data center cabinets.

All production processes are monitored and controlled by the ERP system.

Günko Industrial in the 19" rack industry in 2007 is the first enterprise engaged in the production of the EN standards, has been certified by TSE in 2010.

Its processes related to using the TS EN ISO 9001 Quality Management System and resources more effectively and efficiently control is continuous improvement.

Günko Industrial, within company boundaries, secure workspaces and safety work-related accidents by adopting a culture of prevention policies, to keep under control under the legal requirements and practices regarding enforcement of environmental legislation aims.

Günko Industrial pride of being the preferred brand comes from the excellent services offered to customers.



elegant pro

server rack

elegant net

open

rack

cabinets

pro case

soho rack

accessories

fiber optic

elegant wall

Elegant Wall

Elegant pro

Elegant Net

cabinets

Server

Accessories

fiber optic

Soho

Open Rack

Pro case



woooow!!!

Günko desinged welded frame rack cabinets



We are aware of our responsibilities as Gunko industrial.

Elegant robust structure consist by front and rear welded frames.

19" Elegant Net & Elegant Pro rack cabinets are designed to meet the needs of high density network applications and it is engineered for superior weight capacity with welded construction.



%100 Recyclable packaging Materials

Elegant flat pack racks
less carbon footprint

Green advantages of fat pack

Do not forget your environmental responsibility

Compared to pre-assemble products flat pack rack cabinets is more environmentally conscious and it cuts down on size, which cuts down on shipping costs and also reduces the carbon footprint for a green Nature environment.



Elegant flat pack Rack cabinets enables consumers to assemble a product themselves with a manual instruction, saving significant amounts of money for the customers by reducing shipping and storage costs and for the consumers it offers an easier shape / size to carry.

You can not change the structure of the buildings but you can order Flat pack Elegant rack (all in 1 pack)

Easy transportation for retail customers



Door / Elevator

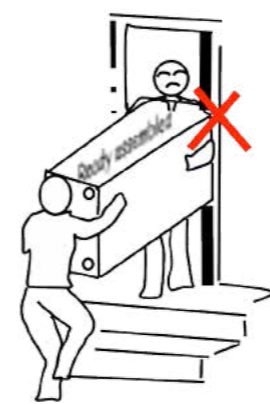

Thanks to Flat pack construction it is possible to bring them also into places with difficult access, e.g. basement or attic, narrow door-openings or spiral stairs.

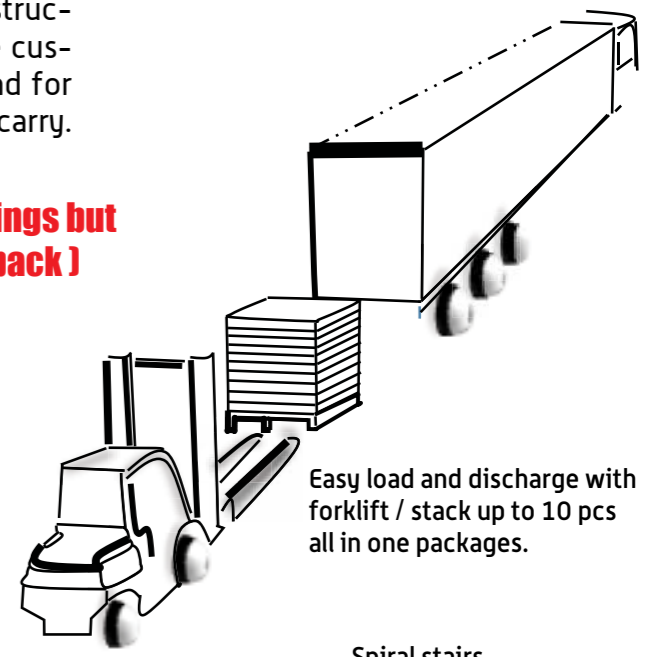

Easy load and discharge with forklift / stack up to 10 pcs all in one packages.

Spiral stairs





Elegant Rack Enclosures

It may be a small part of your total network investment but the right infrastructure enclosures can provide an enormous benefits, you can extend the life of your system by choosing the right enclosure and cooling systems, the product quality makes the difference between success and frustration, as everyone knows the demands of reliable and efficient data transmission requires the highest level of uninterrupted system performance.

We improve our self continuously in order to follow the modern style of today's technology as closely as possible in a harmonisation, Gunko new generation Elegant and server rack models now offers a full range of high-reliability products for networking environments, rack cabinets has been designed for higher density cabling and connectivity system applications and also offers ease, density, availability, affordability and scalability together, it's a well-engineered Rack cabinets offers you a high level of versatility and flexibility for routing high density cable bundles.

Networking enclosures house more equipment when you compared to the past technologies, it is inevitable for us to improve our product range in parallel with innovative communication technology devices and components,

Welded frames are providing an enough robustness for a comfortable storage, Elegant & Server rack cabinets providing a safe housing for your network, its also made a sturdy steel construction for a high load carrying capacity.

Elegant Pro / Elegant Net / Eegant Wall and Server Rack IT cabinets offers the permanent solution for management of Network devices and cables. The unique and effective product range is the ideal solution to support your high cost and valuable network and server devices / equipments with its durable structure, our free standing rack cabinets consist of 4 post mounting rails, the mounting rails and welded frames are typically made of sheet steel, 19 inch mounting rails have square holes that allow you to mount rack equipment to them with screws, you can also use horizontal rails or shelves that you mount in the rack cabinet to provide extra support

Gunko Network and Serer Rack cabinets comply with international standards of EN-61287-1 / IEC 60297 norms, the width of the mounting rails (19 inch), horizontal and vertical measurement of the mounting holes, the size of the equipment cabinets and other measurements has been standardized.

Rack cabinets are designed to solve the problems of today's networking operations with it is large internal volume providing a unique work space and cabling accessibility, modular structure also providing extremely space efficient, saving significant amounts of money for the customers by reducing shipping and storage costs.

Rack cabinets is employed in the most various environments, as industrial installations, IT/ Broadcasting, Telecommunication, railway, military industry, communication and data centers.

Elegant & Server Rack IT rack cabinets are manufactured with different width&depth sizes as mentioned below.

Width : 600mm / 800mm

Depth: 600mm / 800mm / 1000mm

Width : 800mm Elegant cabinets are designed for the purpose of high-density cabling.

Elegant PRO IT Rack Cabinet



**Combination of
elegance and strength**

1

cabineets

www.gunko.com.tr

GÜNKO

Elegant Pro



elegant pro cabinets



Elegant PRO 600
IT Rack Cabinet

Elegant IT rack series offers the permanent solution for management of Network devices and cables. The unique, flexible and effective range is the ideal solution to support the Network and server applications with its welded and durable structure.

Elegant IT rack networking Cabinets are intended for installation of data and telecommunication devices and their distribution systems. Mostly used for structured network cabling systems in office environments, Also to be used in computer-rooms and small or large sized data-centers. A lot of options for doors, side- and rear panels, as well as many different accessories, make the use of the enclosure very flexible.

Removable side and rear panels allow comfortable and easy access to the installed devices for maintenance from all sides of the cabinet. For active cooling it is possible to install an optional fan-unit into the roof or 19inch rack mount type fan units. Thanks to flat-pack construction it is possible to bring them also into places with difficult access, basement or attic, In the narrow entrance or stairs.

Vertical mounting rails are adjustable throughout the entire depth of the cabinet and have high carrying capacity with 1.5mm thickness. Silk-screen mounting rails are providing ability to count U-Marking from top to down & down to up for easy device installation.

| | |
|------------------------------------------------------------------------------------|-----------------------------------|
| We are responding the needs of users with choice of 9 different height dimensions. | Height : 12U-16U-20U-22U-26U-32U |
| | 36U-42U-45U-47U |
| | Width : 600 mm |
| | Depth : 600 mm & 800 mm & 1000 mm |

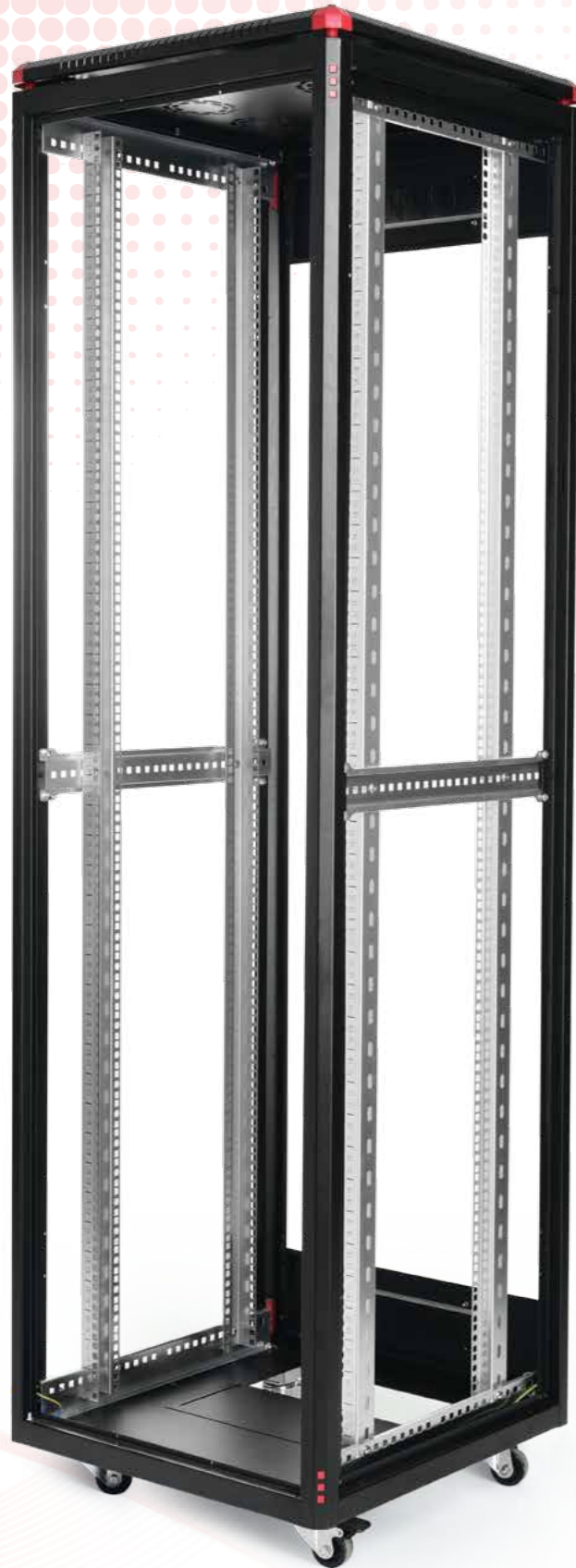

Elegant PRO 600

IT Rack Cabinet

Quick-change fan tray allows accessibility without removing the cables or active devices from the rack in case of any maintenance or replacement needs.

Elegant PRO; The raised top cover has been designed to throw out hot air from the rack and eliminate the risk of dripping water , dust flow , insect entry and also provides a good protection against the unexpected external factors. The ventilation module can be detached by removing 4 pcs screws from the top in case of maintenance or replacement needs.



Protect your device against overheating by choosing the right fan module.

We offer a wide product range of ventilation units with the different fan modules.

On/Off switch Fan modules Analog or digital
Thermostat control unit Fan modules



Rear Cable entry panels with Elegant-Pro



Make it easier with multiple cable entries

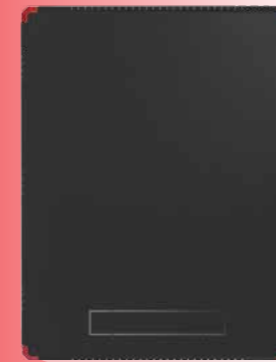

Sliding cable entry panels located on the top cover designed for easy cabling and High-density cabling by using sliding cable entry panels with the dimensions w: 300mm – D: 56 mm



Brushed rear door cable entry panel w: 300mm – D: 56mm dimensions 1 ea Up to 26U and 2pcs on the Highest Elegant-pro Racks.



Sliding cable entry panels located on the bottom plates has been designed for easy cabling and High-density cabling by using sliding cable entry panels with the dimensions w: 300 – D: 125 mm



The vertical mounting rails are adjustable throughout the entire depth of the cabinet and have very high carrying capacity with 1.5mm thickness. Silk-screen mounting rails are providing ability to count U-Marking from top to down & down to up for easy device installation.



Castors

Castor and/or levelling feet could be mounted on to rack.

elegant pro cabinets

Elegant PRO 600

IT Rack Cabinet

Door options / W: 600 mm

The front door is designed to provide security with lock mechanism and decorative view together, full-length smoked and shatterproof glass door deployed left & right frames, easily rotated to the left or right

directions by special spring hinge, in case of needs 3 points and single point locking systems are available depends on customer requirements.

Easi removable side panels complete with Barrel lock & Sliding latch locks

RAL 9005-Black (Standard Colour)
RAL 7035-Light Gray (Optional)



elegant pro cabinets

%80 Curved Perforated Metal Door-Single



%63 Curved Perforated Metal Door-Single



Flat Metal Door-Single



Tempered Glass Door-Single



%80 Perforated Metal Door-Double



%63 Perforated Metal Door-Double

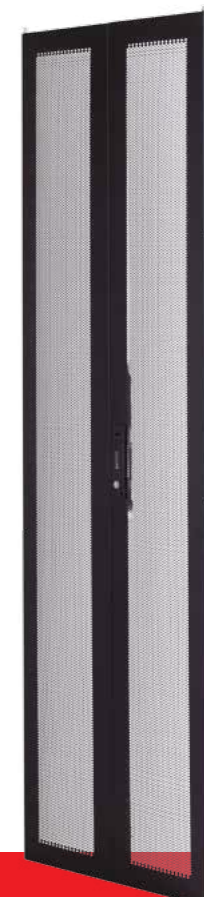

Flat Metal Door-Single



Rear Cable entry panels with
Elegant PRO



Elegant PRO
IT Rack Cabinet



Make it easier with multiple cable entries

Technical Drawing
W: 600 mm d: 600 mm

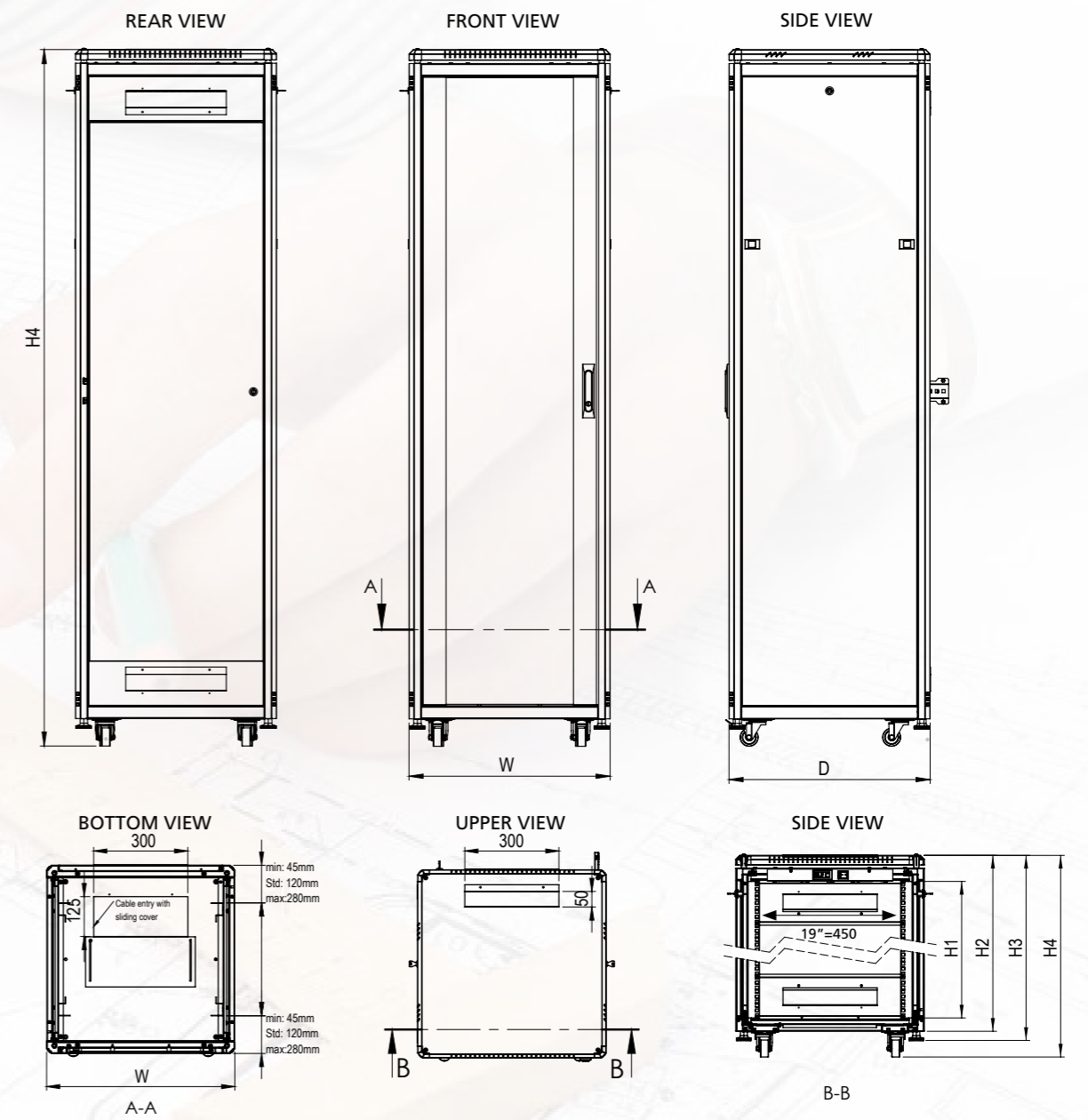
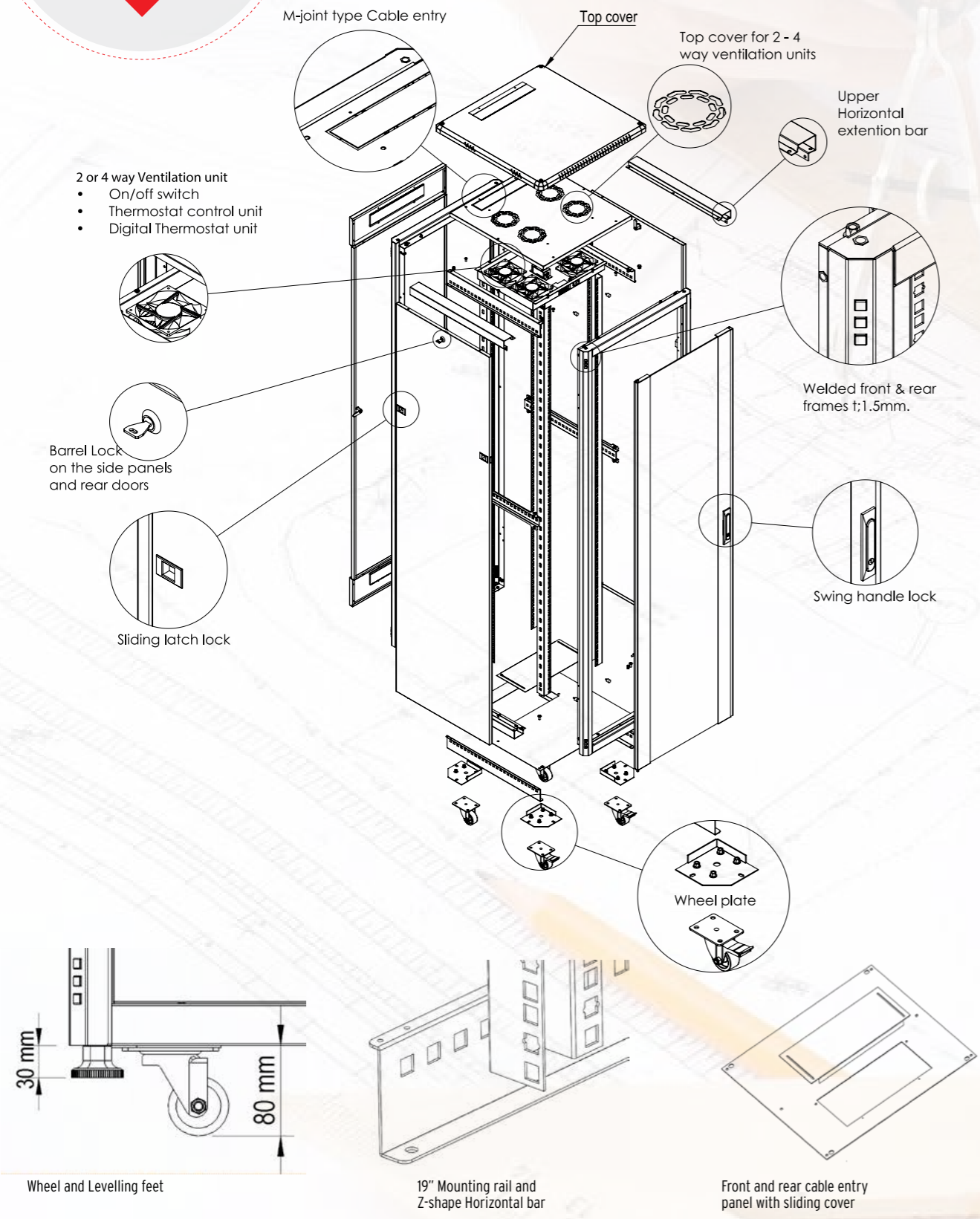

600 x 600 mm FLOOR STANDING ELEGANT PRO RACKS

| Product Code | Product Description | Out Width (W) (mm) | Out Depth (D) (mm) | H:1 Inner Height (mm) | H:2 Out Height without feet & wheel set (mm) | H:3 Out Height with levelling feet (mm) | H:4 Out Height with wheel set (mm) |
|----------------------|---------------------------------------|--------------------|--------------------|-----------------------|----------------------------------------------|-----------------------------------------|------------------------------------|
| ELGP 12U 6060 CC 111 | Elegant PRO 19" 12U W=600 mm D=600 mm | 600 | 600 | 536,6 | 661,4 | 691,4 | 741,4 |
| ELGP 16U 6060 CC 111 | Elegant PRO 19" 16U W=600 mm D=600 mm | 600 | 600 | 714,4 | 839,2 | 869,2 | 919,2 |
| ELGP 20U 6060 CC 111 | Elegant PRO 19" 20U W=600 mm D=600 mm | 600 | 600 | 892,2 | 1017 | 1047 | 1097 |
| ELGP 22U 6060 CC 111 | Elegant PRO 19" 22U W=600 mm D=600 mm | 600 | 600 | 981,1 | 1107 | 1137 | 1187 |
| ELGP 26U 6060 CC 111 | Elegant PRO 19" 26U W=600 mm D=600 mm | 600 | 600 | 1158,9 | 1284,8 | 1314,8 | 1364,8 |
| ELGP 32U 6060 CC 111 | Elegant PRO 19" 32U W=600 mm D=600 mm | 600 | 600 | 1425,6 | 1551,5 | 1581,5 | 1631,5 |
| ELGP 36U 6060 CC 111 | Elegant PRO 19" 36U W=600 mm D=600 mm | 600 | 600 | 1603,4 | 1729,3 | 1759,3 | 1809,3 |
| ELGP 42U 6060 CC 111 | Elegant PRO 19" 42U W=600 mm D=600 mm | 600 | 600 | 1870,1 | 1996 | 2026 | 2076 |
| ELGP 45U 6060 CC 111 | Elegant PRO 19" 45U W=600 mm D=600 mm | 600 | 600 | 2003,45 | 2129 | 2159 | 2209 |
| ELGP 47U 6060 CC 111 | Elegant PRO 19" 47U W=600 mm D=600 mm | 600 | 600 | 2092,35 | 2218 | 2248 | 2298 |

**CC Means=Color Code, BL=Rail 9005 Black, LG=Rail 7035 Light Gray

elegant pro cabinets

Technical Drawing
W: 600 mm D: 800 mm

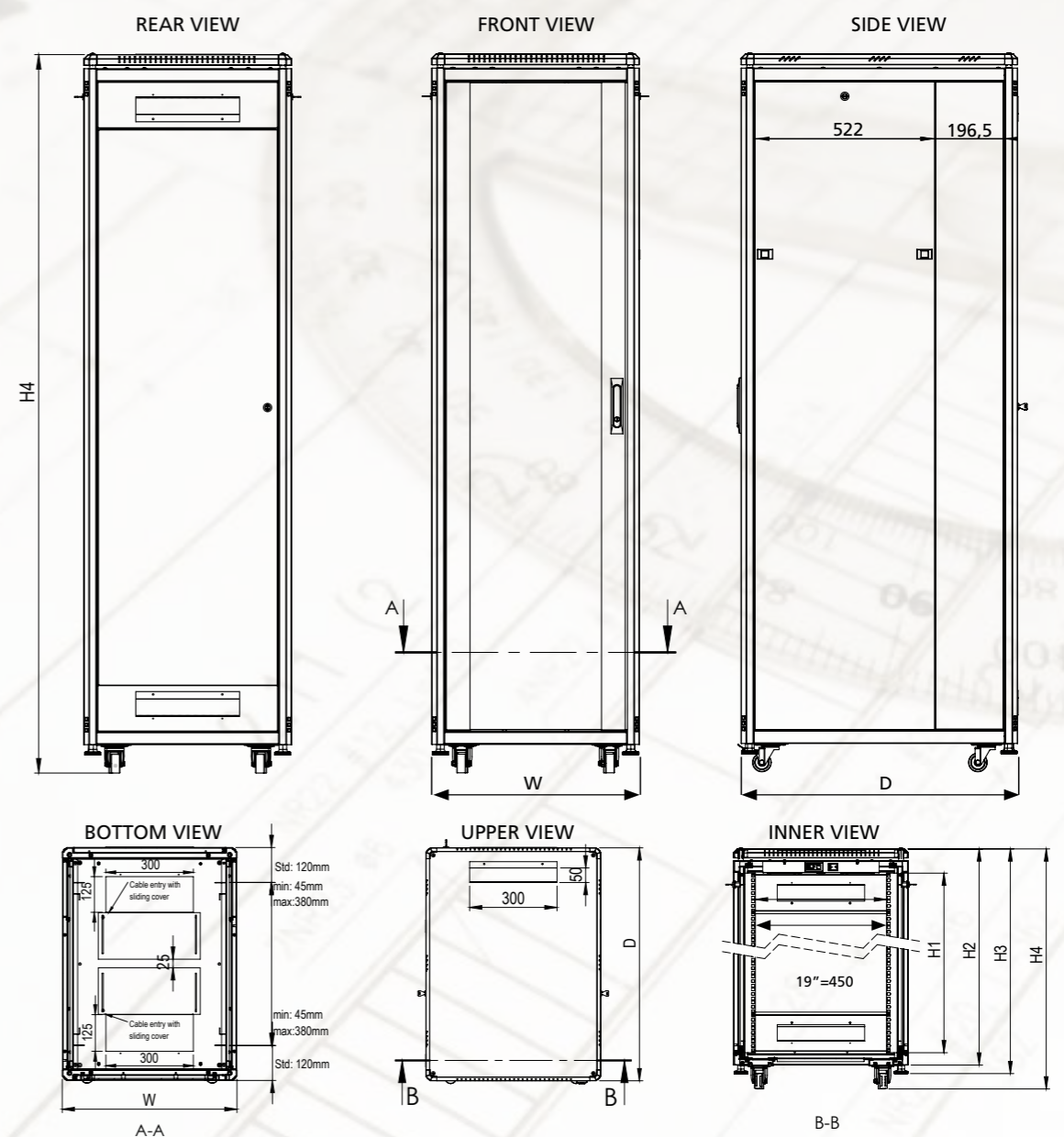
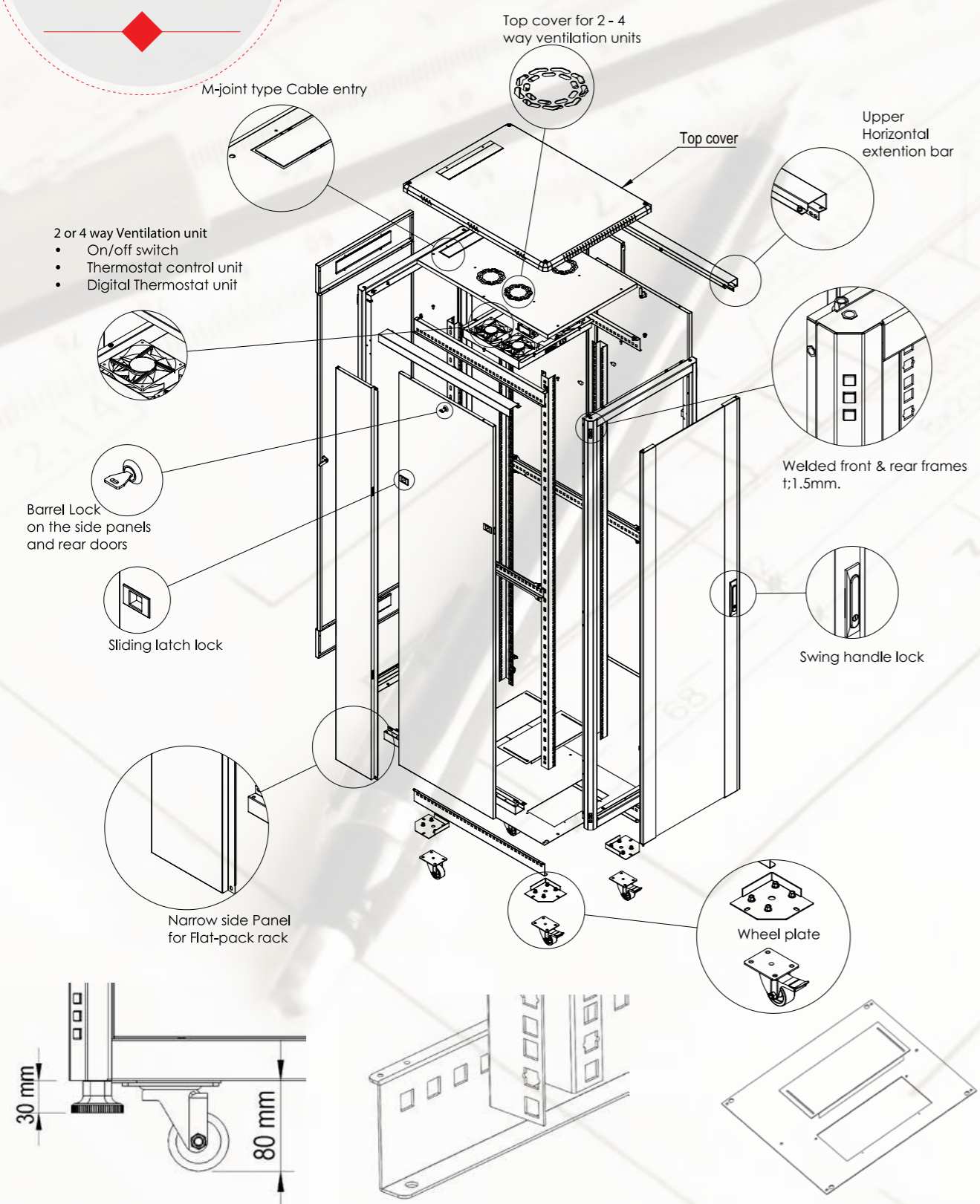

600 x 600 mm FLOOR STANDING ELEGANT PRO RACKS

| Product Code | Product Description | Out Width (W) (mm) | Out Depth (D) (mm) | H:1 Inner Height (mm) | H:2 Out Height without feet & wheel set (mm) | H:3 Out Height with Levelling feet (mm) | H:4 Out Height with wheel set (mm) |
|----------------------|---------------------------------------|--------------------|--------------------|-----------------------|----------------------------------------------|-----------------------------------------|------------------------------------|
| ELGP 12U 6080 CC 111 | Elegant PRO 19" 12U W=600 mm D=800 mm | 600 | 600 | 536,6 | 661,4 | 691,4 | 741,4 |
| ELGP 16U 6080 CC 111 | Elegant PRO 19" 16U W=600 mm D=800 mm | 600 | 600 | 714,4 | 839,2 | 869,2 | 919,2 |
| ELGP 20U 6080 CC 111 | Elegant PRO 19" 20U W=600 mm D=800 mm | 600 | 600 | 892,2 | 1017 | 1047 | 1097 |
| ELGP 22U 6080 CC 111 | Elegant PRO 19" 22U W=600 mm D=800 mm | 600 | 600 | 981,1 | 1107 | 1137 | 1187 |
| ELGP 26U 6080 CC 111 | Elegant PRO 19" 26U W=600 mm D=800 mm | 600 | 600 | 1158,9 | 1284,8 | 1314,8 | 1364,8 |
| ELGP 32U 6080 CC 111 | Elegant PRO 19" 32U W=600 mm D=800 mm | 600 | 600 | 1425,6 | 1551,5 | 1581,5 | 1631,5 |
| ELGP 36U 6080 CC 111 | Elegant PRO 19" 36U W=600 mm D=800 mm | 600 | 600 | 1603,4 | 1729,3 | 1759,3 | 1809,3 |
| ELGP 42U 6080 CC 111 | Elegant PRO 19" 42U W=600 mm D=800 mm | 600 | 600 | 1870,1 | 1996 | 2026 | 2076 |
| ELGP 45U 6080 CC 111 | Elegant PRO 19" 45U W=600 mm D=800 mm | 600 | 600 | 2003,45 | 2129 | 2159 | 2209 |
| ELGP 47U 6080 CC 111 | Elegant PRO 19" 47U W=600 mm D=800 mm | 600 | 600 | 2092,35 | 2218 | 2248 | 2298 |

Wheel and Levelling feet

19" Mounting rail and Z-shape Horizontal bar

Front and rear cable entry panel with sliding cover

Technical Drawing
W:600 mm D:1000 mm

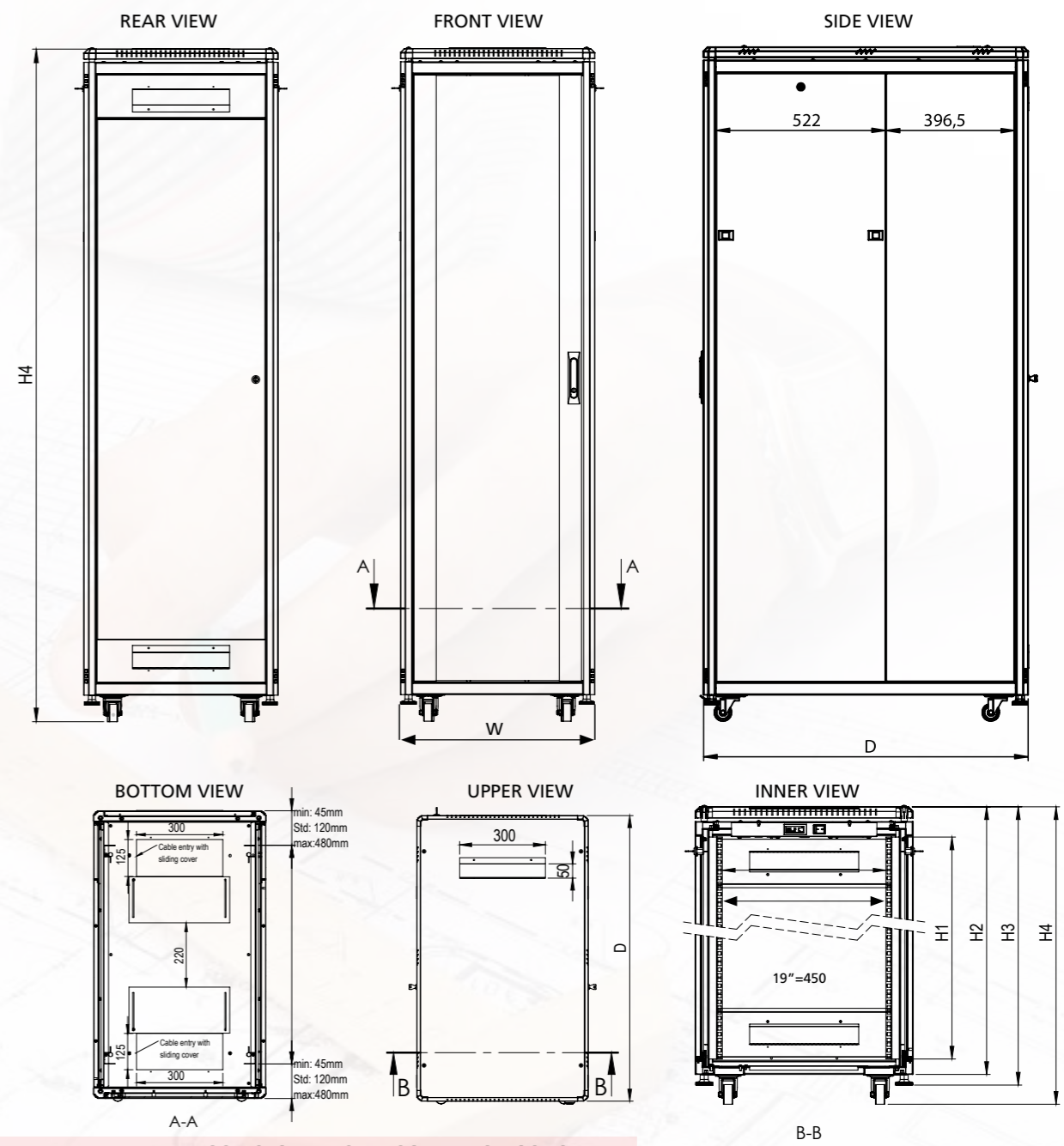
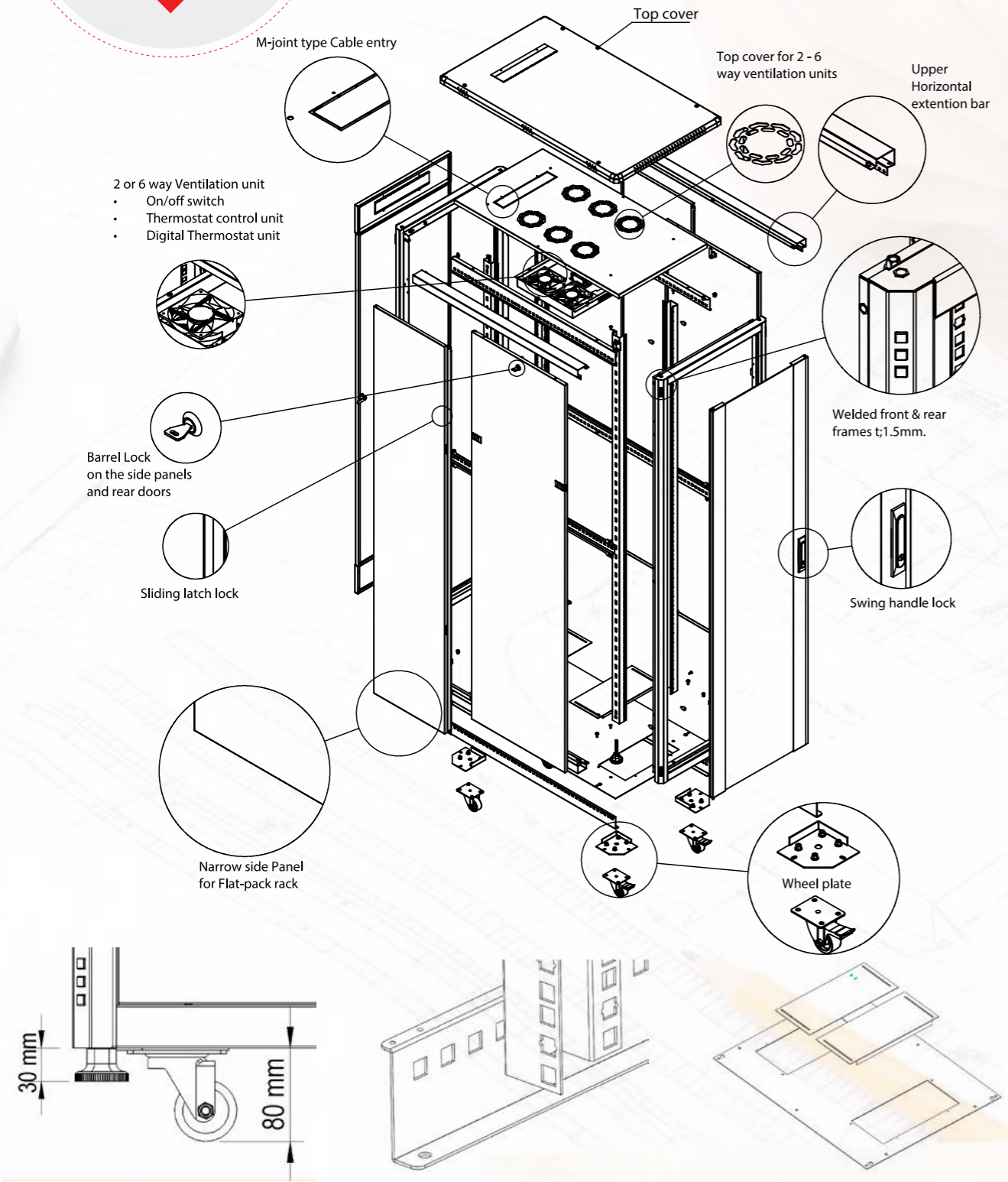

600 x 1000 mm FLOOR STANDING ELEGANT PRO RACKS

| Product Code | Product Description | Out Width (W) (mm) | Out Depth (D) (mm) | H:1 Inner Height (mm) | H:2 Out Height without feet & wheel set (mm) | H:3 Out Height with levelling feet (mm) | H:4 Out Height with wheel set (mm) |
|----------------------|----------------------------------------|--------------------|--------------------|-----------------------|----------------------------------------------|-----------------------------------------|------------------------------------|
| ELGP 12U 6010 CC 111 | Elegant PRO 19" 12U W=600 mm D=1000 mm | 600 | 1000 | 536,6 | 661,4 | 691,4 | 741,4 |
| ELGP 16U 6010 CC 111 | Elegant PRO 19" 16U W=600 mm D=1000 mm | 600 | 1000 | 714,4 | 839,2 | 869,2 | 919,2 |
| ELGP 26U 6010 CC 111 | Elegant PRO 19" 26U W=600 mm D=1000 mm | 600 | 1000 | 1158,9 | 1284,8 | 1314,8 | 1364,8 |
| ELGP 32U 6010 CC 111 | Elegant PRO 19" 32U W=600 mm D=1000 mm | 600 | 1000 | 1425,6 | 1551,5 | 1581,5 | 1631,5 |
| ELGP 36U 6010 CC 111 | Elegant PRO 19" 36U W=600 mm D=1000 mm | 600 | 1000 | 1603,4 | 1729,3 | 1759,3 | 1809,3 |
| ELGP 42U 6010 CC 111 | Elegant PRO 19" 42U W=600 mm D=1000 mm | 600 | 1000 | 1870,1 | 1996 | 2026 | 2076 |
| ELGP 45U 6010 CC 111 | Elegant PRO 19" 45U W=600 mm D=1000 mm | 600 | 1000 | 2003,45 | 2129 | 2159 | 2209 |
| ELGP 47U 6010 CC 111 | Elegant PRO 19" 47U W=600 mm D=1000 mm | 600 | 1000 | 2092,35 | 2218 | 2248 | 2298 |

elegant pro cabinets

Elegant PRO 800

Elegant PRO 800 IT Rack Cabinet

Network installers will be quite satisfied when needed Large internal volume during the installation

Elegant Net IT rack series offers the permanent solution for management of Network devices and cables. The unique, flexible and effective range is the ideal solution to support the Network and server applications with its welded and durable structure.

Elegant IT rack networking Cabinet are intended for installation of data and telecommunication devices and their distribution systems. Mostly used for structured network cabling systems in office environments, Also to be used in computer-rooms and small or large sized data-centers. A lot of options for doors, side- and rear panels, as well as many different accessories, make the use of the enclosure very flexible.

Vertical mounting rails are adjustable throughout the entire depth of the cabinet and have very high carrying capacity with 1.5mm thickness Silk-screen mounting rails are providing ability to count U- Marking from top to down & down to up for easy device installation.

Removable side and rear panels allow comfortable and easy access to the installed devices for maintenance from all sides of the cabinet. For active cooling it is possible to install an optional fan-unit into the roof or 19inch rack mount type fan units. Due to flat-pack construction it is possible to bring them also into places with difficult access, basement or attic, In the narrow entrance or stairs.

Width=800mm Elegant Pro IT rack cabinets are designed for housing the Patch panels , switching installation , patch cord / cable management both horizontally or vertically positions

it allows for cable management of the each side of 19" mounting rails with or without Vertical cable management block / Vertical cable management with sliding panel and its the simple, flexible and cost-effective way to organize your cable bundles and patch cords , The Cabins are optimized to meet the modern network and structured cabling requirements.



We are responding the needs of users with choice of 5 different height dimensions.

Height : 26U-32U-36U-42U-45U-47U
Width : 800mm
Depth : 800mm & 1000mm

Elegant PRO 800

IT Rack Cabinet

Quick-change fan tray allows accessibility without removing the cables or active devices from the rack in case of any maintenance or replacement needs.

Elegant PRO; The raised top cover has been designed to eliminate the risk of dripping water, dust flow, insect entry and also provides a good protection against the unexpected external factors. The ventilation module can be detached by removing 4 pcs screws from the top in case of maintenance or replacement needs.

Protect your device against overheating by choosing the right fan module.

We offer a wide product range of ventilation units with the different fan modules.

On/Off switch Fan modules Analog or digital
Thermostat control unit Fan modules

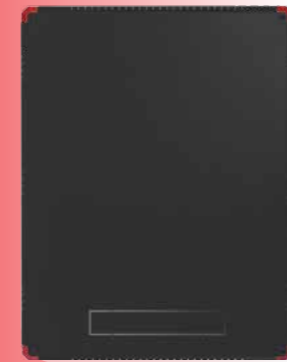

Sliding cable entry panels located on the top cover designed for easy cabling and High-density cabling by using sliding cable entry panels with the dimensions w: 300mm – D: 56 mm



Brushed rear door cable entry panel w: 300mm – D: 56mm dimensions 1 ea Up to 26U and 2pcs on the Highest Elegant-pro Racks.



Sliding cable entry panels located on the bottom plates has been designed for easy cabling and High-density cabling by using sliding cable entry panels with the dimensions w: 300 – D: 125 mm



The vertical mounting rails are adjustable throughout the entire depth of the cabinet and have very high carrying capacity with 1.5mm thickness. Silk-screen mounting rails are providing ability to count U-Marking from top to down & down to up for easy device installation.



Castors

Castor and/or levelling feet could be mounted on to rack.

elegant pro cabinets

Elegant PRO 800

IT Rack Cabinet

Door options / W: 800 mm

The front door is designed to provide security with lock mechanism and decorative view together, full-length smoked and shatterproof glass door deployed in metal frame, easily rotated to the left

or right directions by special spring hinge, in case of needs 3 points and single point locking systems are available with single glass instead of splitted glasses depends on customer requirements.

Easily removable side panels complete with Barrel lock & Sliding latch locks

RAL 9005-Black (Standard Colour)
RAL 7035-Light Gray (Optional)



%80 Curved Perforated Metal Door-Single



%63 Curved Perforated Metal Door-Single



Flat Metal Door-Double



Tempered Glass Door-Double



%80 Perforated Metal Door-Double



%63 Perforated Metal Door-Double



Flat Metal Door-Double



elegant pro cabinets

Technical Drawing
W:800 mm d:800 mm

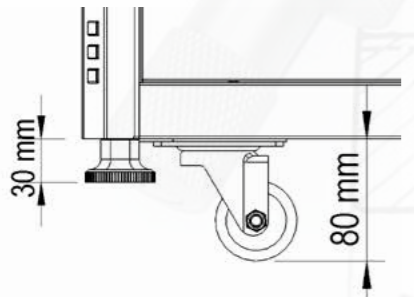
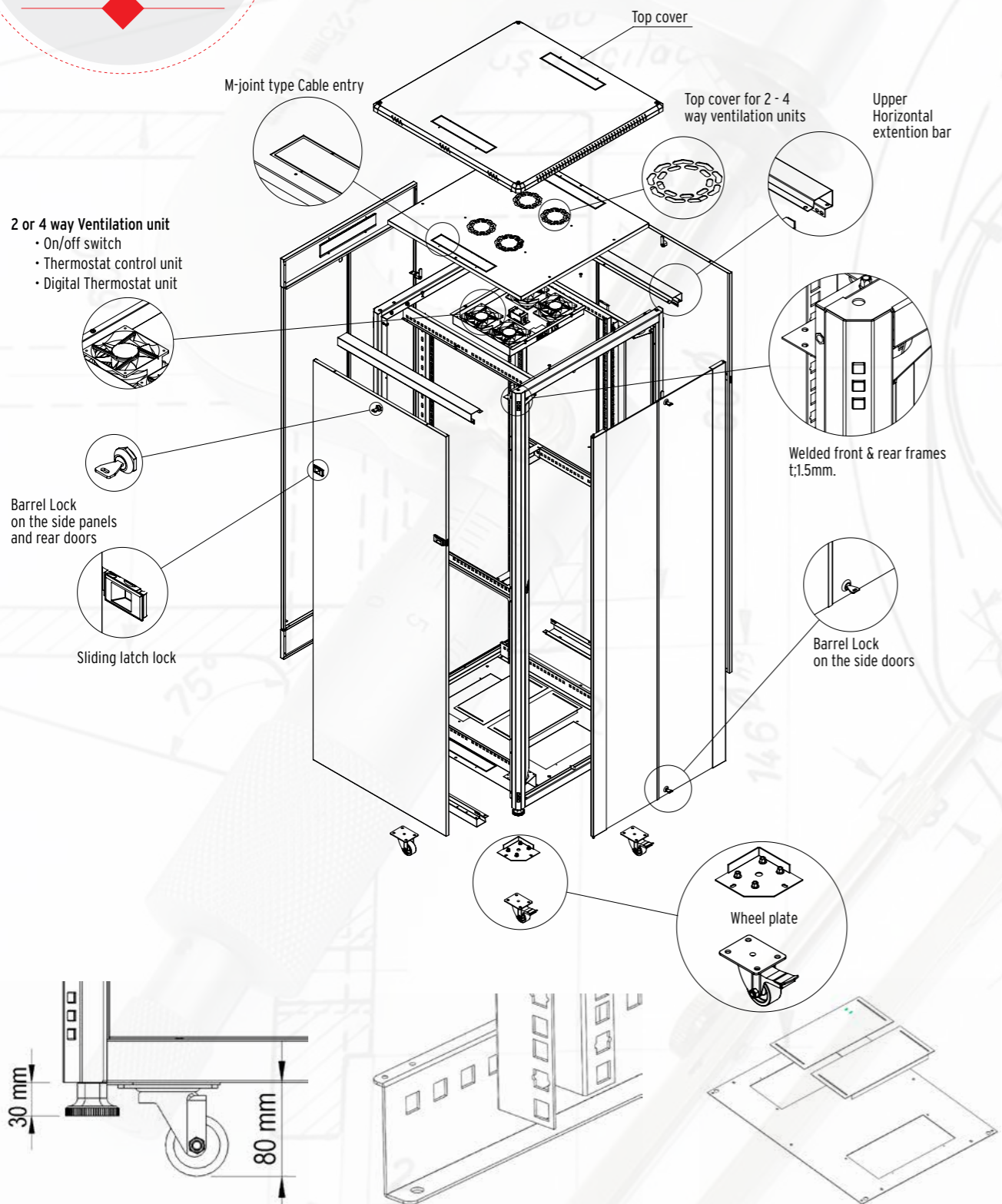

Wheel and Levelling feet



19" Mounting rail and Z-shape Horizontal bar

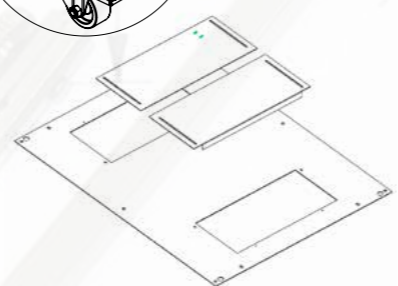

Front and rear cable entry panel with sliding cover

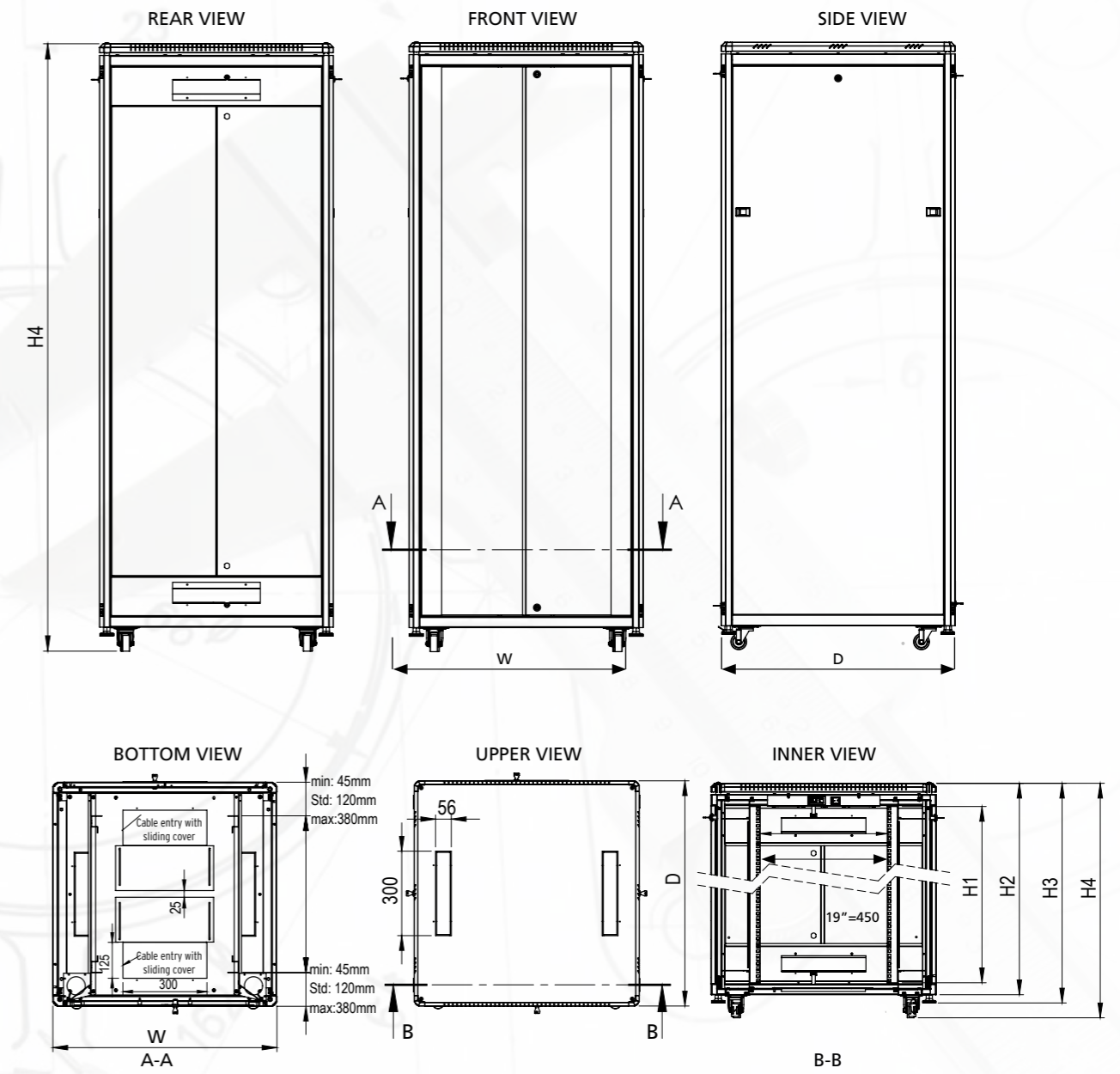

800 x 800 mm FLOOR STANDING ELEGANT PRO RACKS

| Product Code | Product Description | Out Width (W) (mm) | Out Depth (D) (mm) | H:1 Inner Height (mm) | H:2 Out Height without feet & wheel set (mm) | H:3 Out Height with levelling feet (mm) | H:4 Out Height with wheel set (mm) |
|----------------------|---------------------------------------|--------------------|--------------------|-----------------------|----------------------------------------------|-----------------------------------------|------------------------------------|
| ELGP 26U 8080 CC 221 | Elegant PRO 19" 26U W=800 mm D=800 mm | 800 | 800 | 1158,9 | 1284,8 | 1314,8 | 1364,8 |
| ELGP 32U 8080 CC 221 | Elegant PRO 19" 32U W=800 mm D=800 mm | 800 | 800 | 1425,6 | 1551,5 | 1581,5 | 1631,5 |
| ELGP 36U 8080 CC 221 | Elegant PRO 19" 36U W=800 mm D=800 mm | 800 | 800 | 1603,4 | 1729,3 | 1759,3 | 1809,3 |
| ELGP 42U 8080 CC 221 | Elegant PRO 19" 42U W=800 mm D=800 mm | 800 | 800 | 1870,1 | 1996 | 2026 | 2076 |
| ELGP 45U 8080 CC 221 | Elegant PRO 19" 45U W=800 mm D=800 mm | 800 | 800 | 2003,45 | 2129 | 2159 | 2209 |
| ELGP 47U 8080 CC 221 | Elegant PRO 19" 47U W=800 mm D=800 mm | 800 | 800 | 2092,35 | 2218 | 2248 | 2298 |

**CC Means=Color Code, BL=Rall 9005 Black, LG=Rall 7035 Light Gray

elegant pro cabinets

Technical Drawing
w:800 mm d:1000 mm

elegant pro cabinets

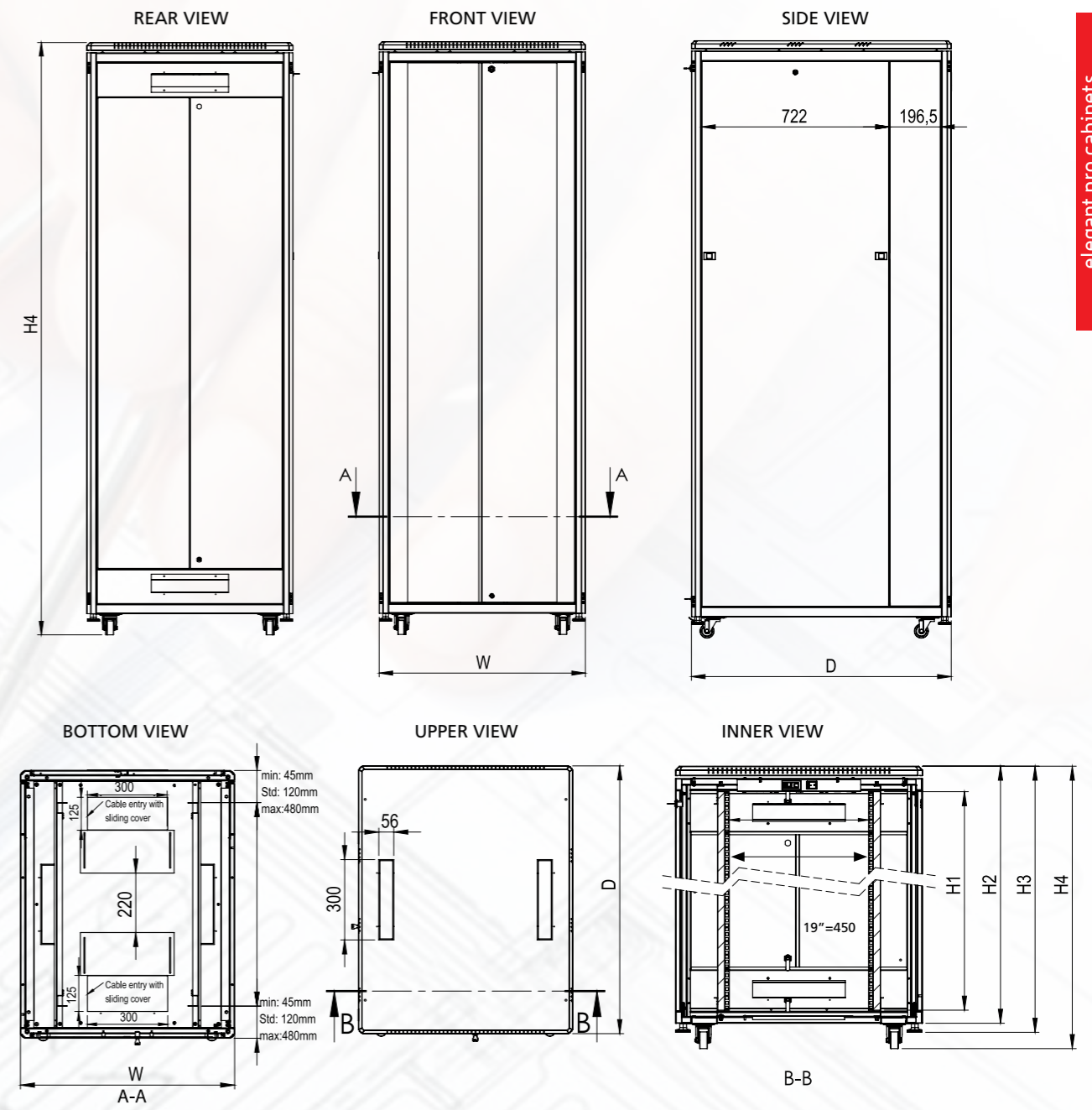
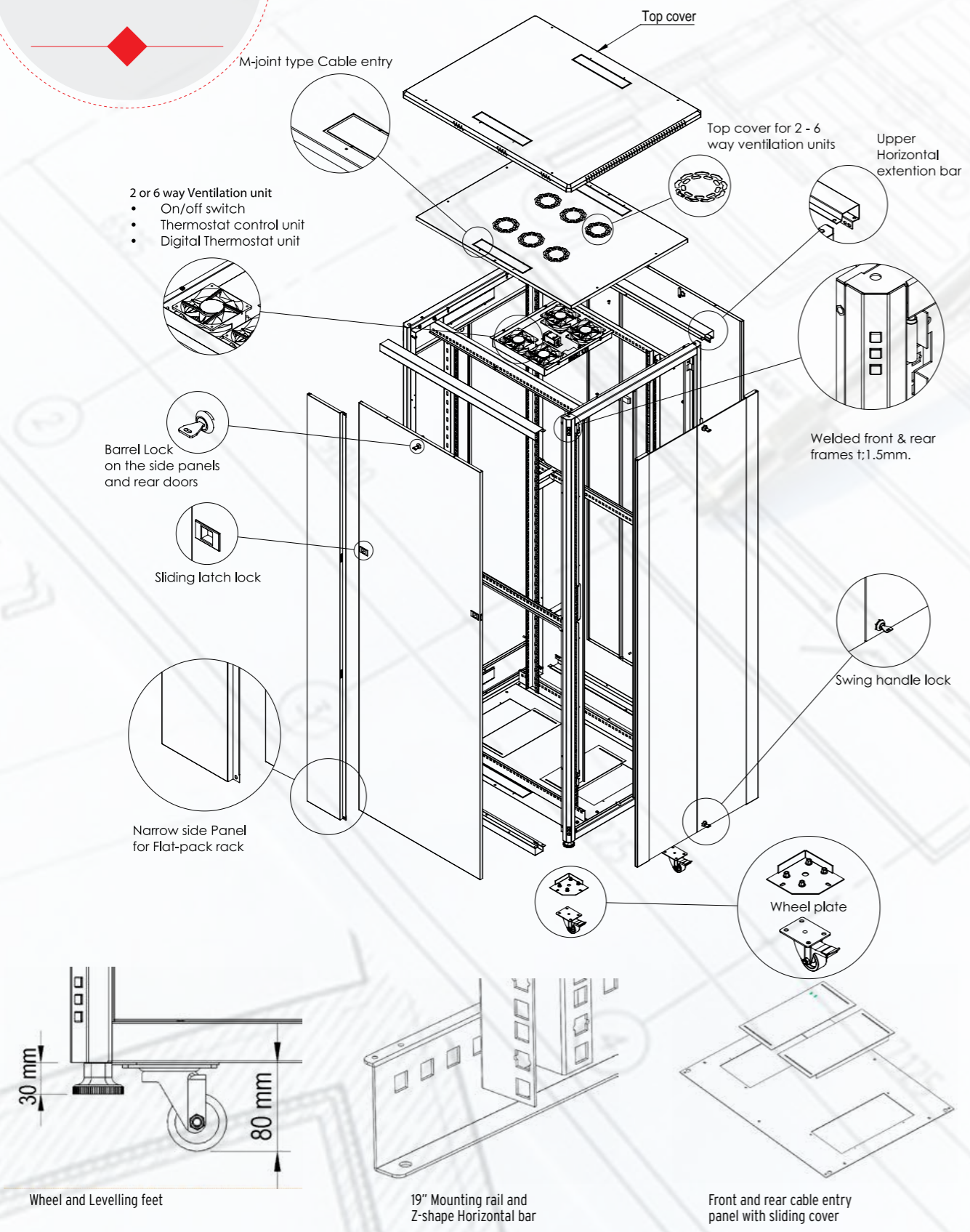

800 x 1000 mm FLOOR STANDING ELEGANT PRO RACKS

| Product Code | Product Description | Out Width (W) (mm) | Out Depth (D) (mm) | H:1 Inner Height (mm) | H:2 Out Height without feet & wheel set (mm) | H:3 Out Height with levelling feet (mm) | H:4 Out Height with wheel set (mm) |
|----------------------|----------------------------------------|--------------------|--------------------|-----------------------|----------------------------------------------|-----------------------------------------|------------------------------------|
| ELGP 26U 8010 CC 111 | Elegant PRO 19" 26U W=800 mm D=1000 mm | 800 | 1000 | 1158,9 | 1284,8 | 1314,8 | 1364,8 |
| ELGP 32U 8010 CC 111 | Elegant PRO 19" 32U W=800 mm D=1000 mm | 800 | 1000 | 1425,6 | 1551,5 | 1581,5 | 1631,5 |
| ELGP 36U 8010 CC 111 | Elegant PRO 19" 36U W=800 mm D=1000 mm | 800 | 1000 | 1603,4 | 1729,3 | 1759,3 | 1809,3 |
| ELGP 42U 8010 CC 111 | Elegant PRO 19" 42U W=800 mm D=1000 mm | 800 | 1000 | 1870,1 | 1996 | 2026 | 2076 |
| ELGP 45U 8010 CC 111 | Elegant PRO 19" 45U W=800 mm D=1000 mm | 800 | 1000 | 2003,45 | 2129 | 2159 | 2209 |
| ELGP 47U 8010 CC 111 | Elegant PRO 19" 47U W=800 mm D=1000 mm | 800 | 1000 | 2092,35 | 2218 | 2248 | 2298 |

**CC Means=Color Code, BL=Rall 9005 Black, LG=Rall 7035 Light Gray

Choice of professionals

elegant pro kabinler

Elegant PRO
IT Rack Cabinet

W600
Curved Perforated

FRONT VIEW



REAR VIEW



FRONT VIEW



REAR VIEW

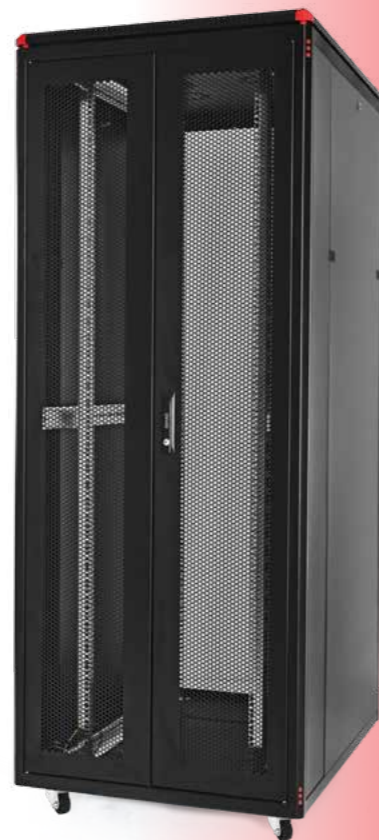

W800
Curved Perforated

