



PAL3004
4-Zone Extinguishant Control Panel
EN54-2, EN54-4, PSI

Technical specification:

ITEM	ELECTRICAL RATING	Note
Size	383mm W x 295mm H x 87mm D metal enclosure	
Weight	5kg	
Mains supply	90 to 270VAC, 50Hz/60Hz	
Mains supply fuse	3 Amp (F3A L250V)	Replace only with similar type
Power supply rating	3 Amps total including battery charge 28V +/- 2V	
Maximum ripple voltage	≤200 millivolts	
Battery type	Two 12 Volt sealed lead acid in series.	7Ah maximum
Battery charge voltage	27.6VDC nomina	
Battery charge current	0.7A maximum	
Current draw in mains fail condition	0.095 Amps	With buzzer sounding
Current draw in second stage alarm	0.235Amps	Two zones in fire (470 ohm in circuit)
Current draw in post discharge condition	0.310Amps	solenoid outputs active
Maximum current draw from batteries	3Amps	With main power disconnected
NAC outputs (sounder & bell circuit)	26 to 28V DC Fused at 500mA with electronic fuse	1.2Amp total load over all circuits
Fault relay contact rating	2A /30VDC maximum for each	Volt free changeover contact
Fire relay contact rating	2A /30VDC maximum for each	Volt free changeover contact
First stage contact rating	2A /30VDC maximum for each	Volt free changeover contact
Second stage contact rating	2A /30VDC maximum for each	Volt free changeover contact
Extract contact rating	2A /30VDC maximum for each	Volt free changeover contact
Zone quiescent current	4mA maximum	
Terminal capacity	0.5mm ² to 2.5mm ² solid or stranded wire	
Number of detectors per zone	≤30 PCS conventional detectors	
Number of sounders per circuit	Dependent on type and current consumption	
Detection circuit end of line	4K7±5% 1/2-Watt resistor	
Monitored input end of line	4K7±5% 1/2-Watt resistor	
Sounder circuit end of line	10K±5% 1/2-Watt resistor	
Extinguishant output end of line	10K±5% 1/2-Watt resistor	
No. of detection circuits	Four 21 to 28V DC	
No. of sounder circuits	Four 21 to 28V DC	
Extinguishant release output	21V to 28V DC. Maximum load 2 Amp	
Extinguishant release delay time	Adjustable 0 to 75 seconds	5 second steps
SIL, AL, FLT, RST inputs	Switched – min resistance 0 ohms, max 1k ohms	
Detector alarm threshold	270 ohms to 1K ohms	
Call point alarm threshold	150 ohms to 1K ohms	
Short circuit threshold	0 ohms to 130 ohms	
Status unit/Ancillary board connection	Two wire RS485 connection with electronic fuse.	Max. of 32 units-RS485 data cable

Description:

The automatic extinguisher control panel is designed in accordance with standards EN54-2 and EN54-4 Fire Detection and Fire Alarm systems - Control and Indicating Equipment and EN12094-1 Fixed firefighting systems - Components for gas extinguishing systems - Part 1: Requirements and test methods for electrical automatic control and delay devices.

The control equipment is a combined fire alarm control panel and extinguishing system and has four detection zones, any or all of which are capable of contributing to the extinguishant release decision.

Control panels have an integral, mains powered battery charger and power supply designed in accordance with the requirements of EN54-4.

Notes:

- Two crossing zones (default Zone1 and Zone2), two additional conventional zones (Zone3 and Zone 4).
- Two stages. Stage1 activate NAC1, Stage2 activate NAC2.
- Delay time "Default 30 Sec". it can be changed by DIP switches.
- Manual release button delay time = 10 Sec.
- Disable Zones, NAC1 or NAC2 by DIP Switches. **PLEASE** After changing DIP Switch Turn OFF the Power and the Battery then Turn on the panel and connect the battery again.
- To Reset the panel, enable the Key switch, then press reset

4-ZONES EXTINGUISHER CONTROL PANEL SYSTEM SCHEMATIC

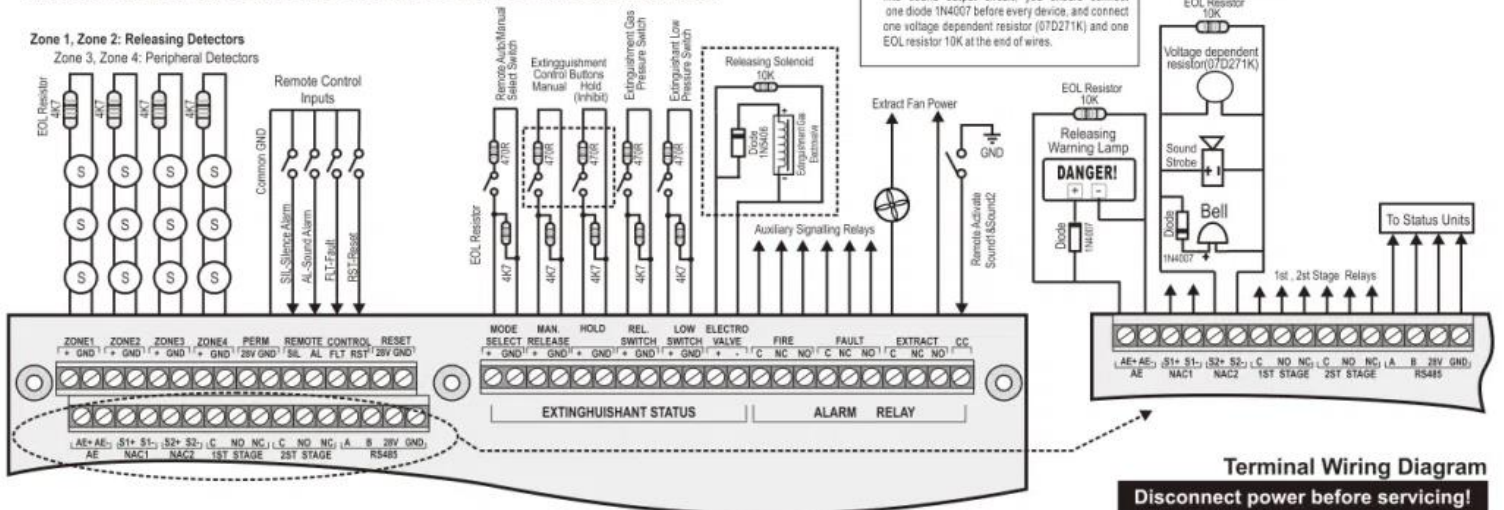

Delay Time Setting (SW2): ON-1, OFF-0

Switch Setting	1	2	3	4	Delay Time(Second)	1	2	3	4	Delay Time(Second)	1	2	3	4	Delay Time(Second)
0 0 0 0	0	0	0	0	0 S	0	0	0	0	1	0	0	0	1	60 S
1 0 0 0	1	0	0	0	5 S	1	0	0	0	1	1	0	0	1	65 S
0 1 0 0	0	1	0	0	10S	0	1	0	0	1	1	0	0	1	70S
1 1 0 0	1	1	0	0	15S	1	1	0	0	1	1	0	0	1	75S

Mains supply: 90 to 270VAC, 50Hz/60Hz
Mains supply fuse: 3 Amp (F3A L250V)
Power supply rating: 3 Amps total including battery charge 28V +/- 2V
Battery type: Two 12 Volt sealed lead acid in series.
See instruction for installation manual.

