

# DATA SHEET

## Weatherproof Conventional Xenon Fire Alarm Strobe Sounder

Part Number

FAE050033



### OVERVIEW

Weather proof Conventional Fire Strobe Sounder is an audible and visual device which requires one single installation point. It's ideal for use where higher noise levels require the use of a more powerful sounder.

### KEY FEATURES

- Designed for outdoor use
- Easy to wire and install
- High-efficiency red LEDs
- Sound pressure level can adjustable.

### TECHNICAL SPECIFICATION

Product Name	Wired Fire Alarm Strobe Sounder
Operating Voltage	12 / 24 VDC
Alarm Current	< 60mA
Sound Pressure	>80 dB
Audio source	8 tones and light combination
Light flash cycle	< 1.3 sec
Working Temperature	-20 °C – 50 °C
Installation way	Wall Hanging
Alarm indicator	Red LED Light
Operating humidity	95% RH
Storage Temperature	-20 °C – 60 °C
Color	Red



### DIMENSIONS

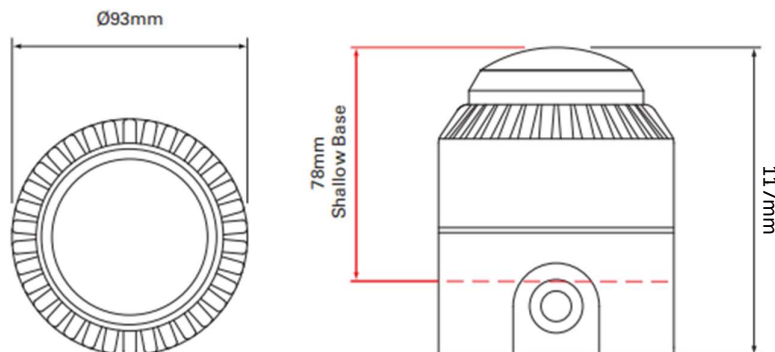

# CONNECTIONS

